

Features

- Max Output Voltage Programmable
- 0~10V dimmable
- IP66



Description

SDD-AAPNx works with 0~10V dimmable driver. The standard features include: the maximum output voltage programmable and 0~10V dimming input compatible. This feature allows the user to set the max output current of the driver with 0-10V dimming still capable.

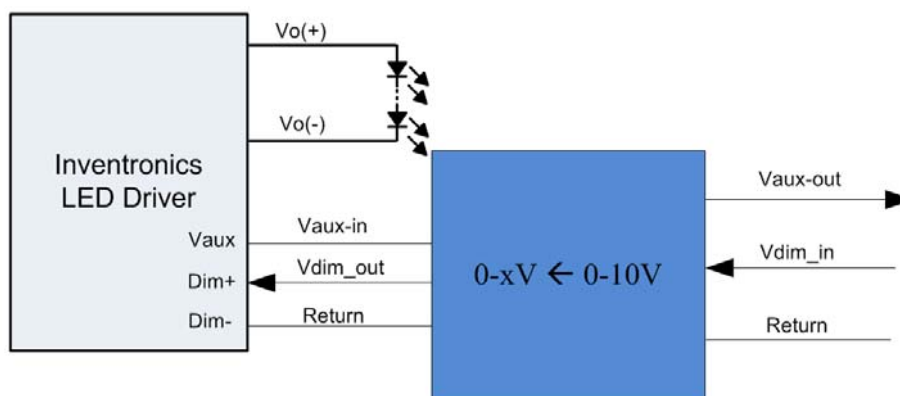

Models

Connection to LED driver	Connection to Controller	P/N ⁽¹⁾	Notes
UL Wire(black/white, purple, gray) with flying leads	UL Wire(yellow, pink, gray) with flying leads	SDD-AAPN1	Default Setting:1-9V Curve, when it is Maximum Value Setting, each step is 5%, duration=2 s, the lowest setting is 50%
UL Wire with UL female connector	UL Wire(yellow, pink, gray) with flying leads	SDD-AAPN2	
UL Wire with UL female connector	UL Wire with UL male connector	SDD-AAPN3	
VDE Wire(black/white, purple, gray) with flying leads	VDE Wire(yellow, pink, gray) with flying leads	SDD-AAPN4	
VDE Wire with UL female connector	VDE Wire(yellow, pink, gray) with flying leads	SDD-AAPN5	
VDE Wire with UL female connector	VDE Wire with UL male connector	SDD-AAPN6	

Note: (1) A suffix –xxxx may be added to denote variations or modifications to the base product, where x can be any alphanumeric character or blank.

Programmer Model

Name	Description	P/N	Notes
Programmer	Programmer with calibration	SDD-AAPNP	Use this device to set the maximum value and calibrate for SDD-AAPNx. Please check the details in the datasheet of SDD-AAPNP.

Архангельск (8182)63-90-72	Ижевск (3412)26-03-58	Магнитогорск (3519)55-03-13	Пермь (342)205-81-47	Сургут (3462)77-98-35
Астана (7172)727-132	Иркутск (395)279-98-46	Москва (495)268-04-70	Ростов-на-Дону (863)308-18-15	Тверь (4822)63-31-35
Астрахань (8512)99-46-04	Казань (843)206-01-48	Мурманск (8152)59-64-93	Рязань (4912)46-61-64	Томск (3822)98-41-53
Барнаул (3852)73-04-60	Калининград (4012)72-03-81	Набережные Челны (8552)20-53-41	Самара (846)206-03-16	Тула (4872)74-02-29
Белгород (4722)40-23-64	Калуга (4842)92-23-67	Нижегород (831)429-08-12	Санкт-Петербург (812)309-46-40	Тюмень (3452)66-21-18
Брянск (4832)59-03-52	Кемерово (3842)65-04-62	Новокузнецк (3843)20-46-81	Саратов (845)249-38-78	Ульяновск (8422)24-23-59
Владивосток (423)249-28-31	Киров (8332)68-02-04	Новосибирск (383)227-86-73	Северодвинск (8692)22-31-93	Уфа (347)229-48-12
Волгоград (844)278-03-48	Краснодар (861)203-40-90	Омск (3812)21-46-40	Симферополь (3652)67-13-56	Хабаровск (4212)92-98-04
Вологда (8172)26-41-59	Красноярск (391)204-63-61	Орел (4862)44-53-42	Смоленск (4812)29-41-54	Челябинск (351)202-03-61
Воронеж (473)204-51-73	Курск (4712)77-13-04	Оренбург (3532)37-68-04	Сочи (862)225-72-31	Череповец (8202)49-02-64
Екатеринбург (343)384-55-89	Липецк (4742)52-20-81	Пенза (8412)22-31-16	Ставрополь (8652)20-65-13	Ярославль (4852)69-52-93
Иваново (4932)77-34-06	Киргизия (996)312-96-26-47	Казахстан (772)734-952-31	Таджикистан (992)427-82-92-69	

Interface Specifications (SDD-AAPNx)

Parameter	Min.	Typ.	Max.	Notes
Vaux_in Voltage	10 V	12 V	13.2 V	
Vaux_in Current	0.01 A	-	0.32 A	
Vdim_in Voltage	-20 V	0-10 V	20 V	
Vdim_in Output Current	0 uA	0.5 uA	1 mA	Pull-up Resistor, Related to Vdim_in
Vdim_in Voltage	0	-	10 V	0~10V Dimming
Vdim_in Voltage Setting	11.3 V	-	-	Step programming mode
Vdim_in Voltage Setting exit	-	-	10.2 V	
Step Duration	-	2 s	-	
Vaux_out Voltage	Vaux_in-1 V	-	Vaux_in	
Vaux_out Sourcing Current	0	-	0.3 A	Vaux_in current > 0.31A
	0	-	(Vaux_in current - 10) mA	Vaux_in current ≤ 0.31A

Maximum Value Setting

There are two ways to set maximum value. One is pulling up Vdim_in to higher than 11.3V and go to step programming mode, the other is using programmer.

Dimming 0~10V Input/Output

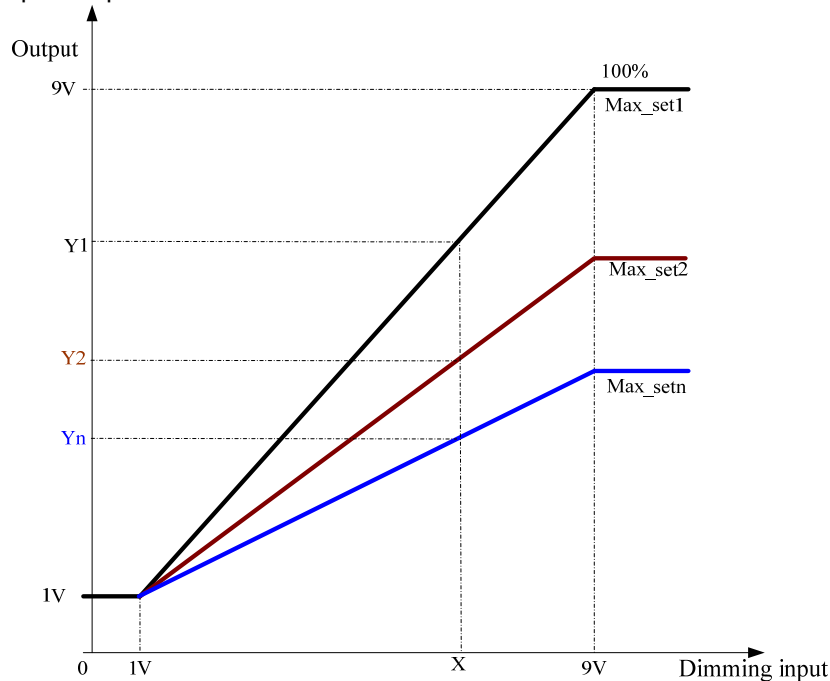

1. Step programming mode

When Vdim_in voltage is higher than 11.3V (should be lower than 20V), it will enter Step programming mode; when Vdim_in voltage is lower than 10.2V, it will enter Dimming Mode. The default settings: Maximum Value Setting, each step is 5%, duration= 2 s, the lowest setting is 50%. The following is Schematic diagram.

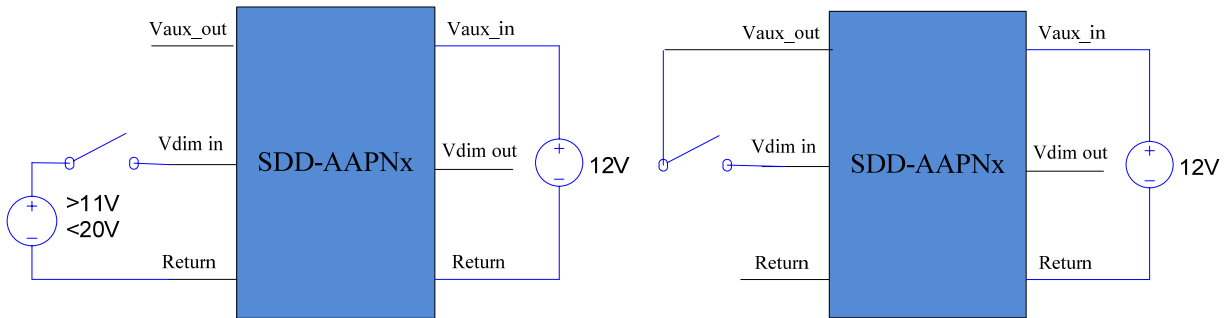

The diagram of Maximum input and output setting is as follows:

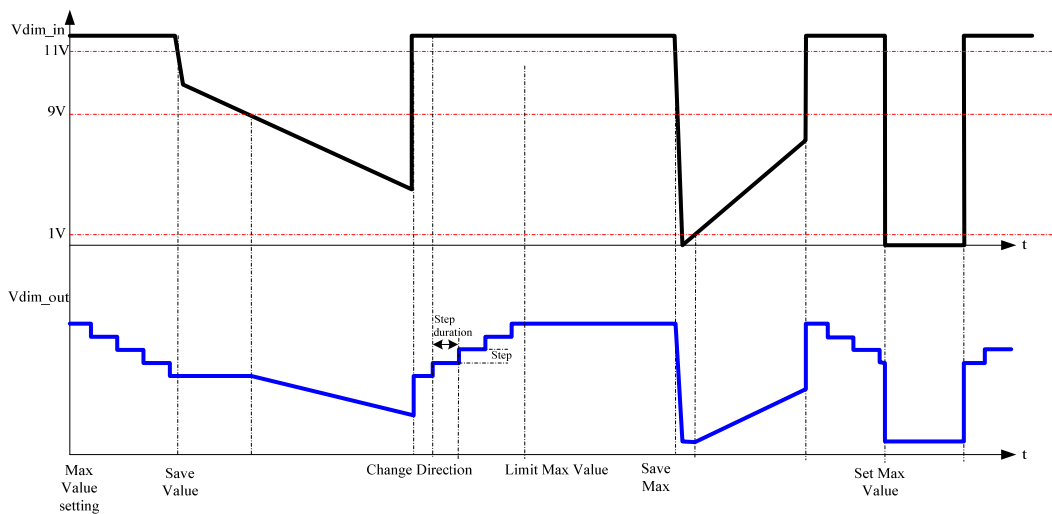

2. Programmer with calibration via PC

Example:

The following is the detailed settings in the below picture:

LED driver model: EUC-075S105DT

Maximum current setting: 0.9A

Dimming setting: 0-10V dimming



Item	Name	Description	Note
1	Communication Port	If only one programmer is connected, it will be set automatically.	
2	中文界面	Shift to Chinese Version	
3	Open CFG	Load the user setting configuration file from PC	
4	Save CFG	Save the user setting configuration file to PC	
5	Series	Select the LED driver series, then set driver model	
6	Model	Select the driver model	
7	Select Maximum Value	Set the maximum value	
8	Program	Write the maximum value with calibration	

2.1 System Setup

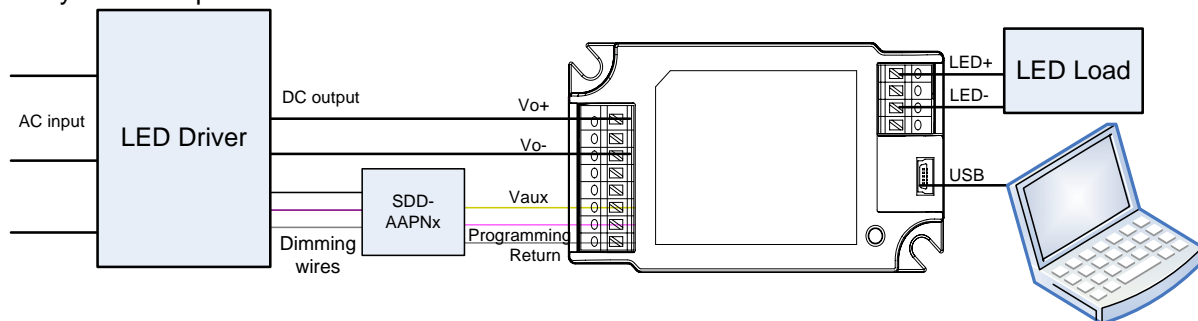

2.2 LED indicator

LED	Status
Green	Powered and idle
Red	Error

2.3 Program Sequence

- 2.3.1 Install the drivers for USB and MSCOMM if PC does not have drivers. This step just needs to do once for one PC.
- 2.3.2 Connect PC, programmer, SDD-AAPNx and LED driver. The LED indicator of programmer will turn Green.
- 2.3.3 Run software of programmer interface. While using the software of programmer interface on the network, if the websites has a higher version, it will remind you whether to update it or not. If you click "Update" and it is updated successfully, the higher version will run, otherwise the old version runs. If the programmer is connected wrongly or the drivers are not installed or the port number is higher than 16(this port number must be lower than or equivalent as 16), the software cannot be opened successfully. Please check it, and then run the software again. If the port number is higher than 16, please modify it to be lower than or equivalent as 16.
- 2.3.4 The USB serial port number in port setting is set automatically. Second number is baud rate and always 9600.



2.3.5 Select the LED driver series and model same as the one connected and set desired maximum value.

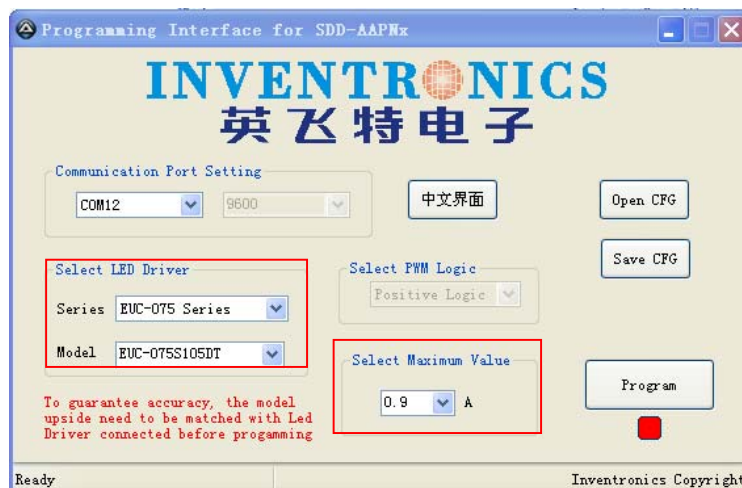

2.3.6 If the configuration exists, it can be loaded by click "Open CFG" directly. The configuration can be saved as a file by click "Save CFG".



2.3.7 Click “Program” button to write the configuration to product. If there is something wrong, interface of “warning” and red indicator is shown. If programming is successful, the green indicator is shown.



2.3.8 Program next one after changing SDD-AAPNx or LED driver. Repeat this step until all the products are programmed.

2.3.9 Shift to Chinese interface by click the “中文界面” if needed.

And back to English interface by click “English” button.





Important Note:

SDD-AAPNx is suggested to be set by the programmer to achieve great output accuracy. SDD-AAPNx should be re-programmed if SDD-AAPNx or LED driver is changed.

General Specifications

Parameter	Min.	Typ.	Max.	Notes
Dimensions Inches (H x D) Millimeters (H x D)		1.5 x 0.63 38 x 16		
Net Weight	-	40 g	-	

Environmental Specifications

Parameter	Min.	Typ.	Max.	Notes
Operating Temperature	-40 °C	-	+70 °C	Humidity: 10%RH to 100%RH.
Storage Temperature	-40 °C	-	+70 °C	Humidity: 5%RH to 100%RH.

Mechanical Outline

SDD-AAPN1

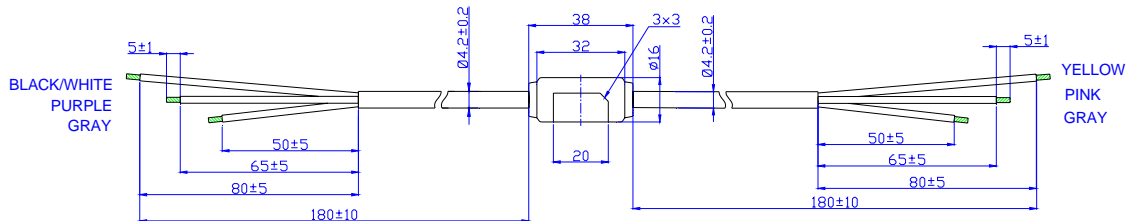

INPUT UL2464 22AWGx3C

OUTPUT UL2464 22AWGx3C

SDD-AAPN2

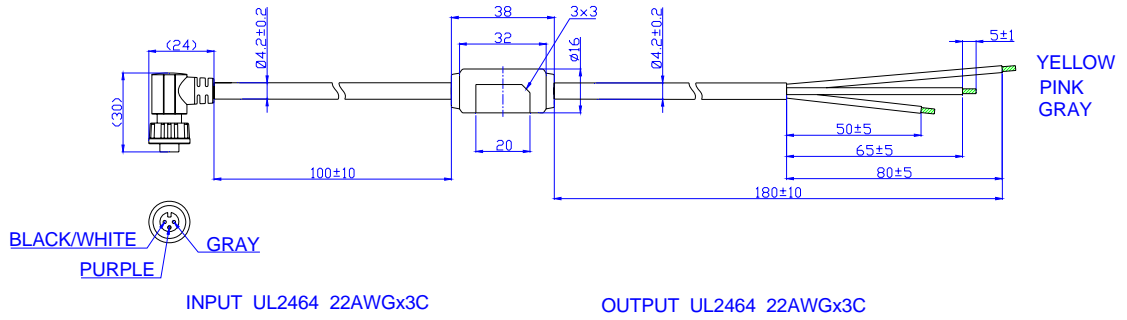

SDD-AAPN3

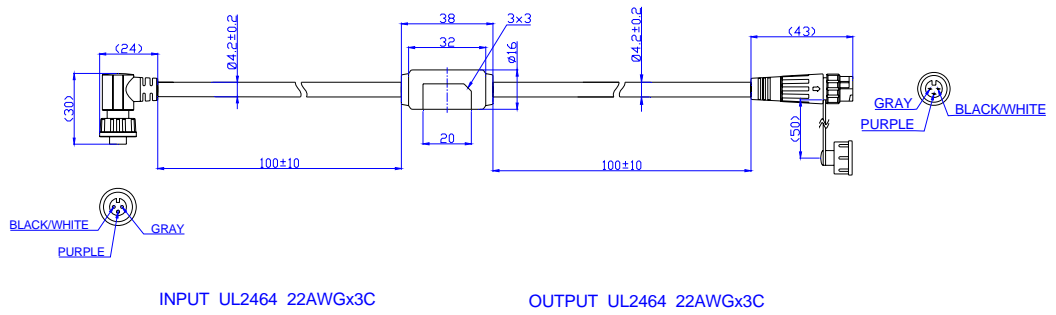

SDD-AAPN4

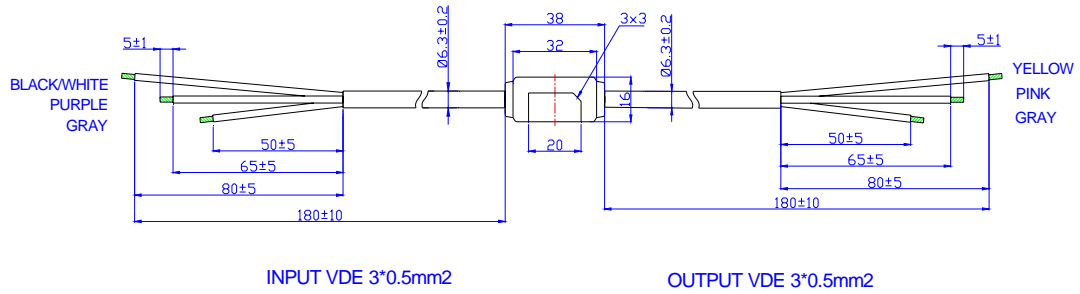

SDD-AAPN5

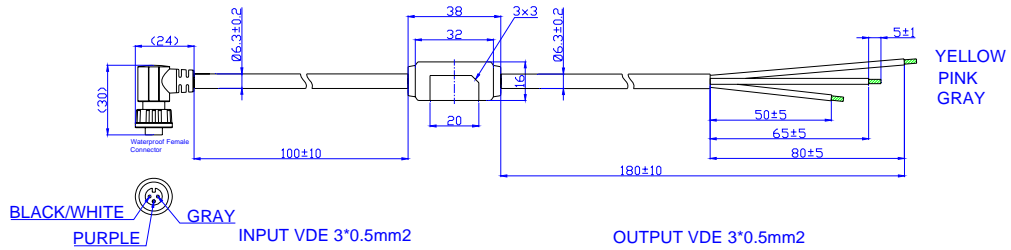

SDD-AAPN6

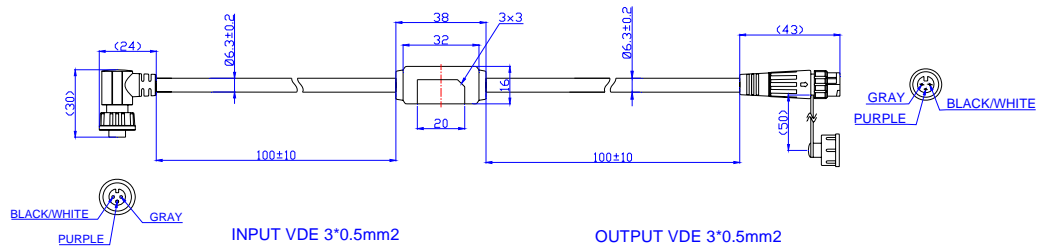

Function definition of interface

Connection to LED driver			Connection to Controller		
Wire Color	Function	Connection	Wire Color	Function	Connection
BLACK/WHITE	Vaux_in	To LED driver's auxiliary power	YELLOW (BLACK/WHITE)	Vaux_out	Auxiliary Power for external circuit
PURPLE	Vdim_out	To LED driver's dimming	PINK (PURPLE)	Vdim_in	Dimming signal input /programming input
GRAY	Return	Return for auxiliary power and dimming signal	GRAY	Return	Return for auxiliary power and dimming signal

Application Note

This 0-xV Controller can only work with 0-10V Dimmable LED drivers. Below is the list.

LED Series Can Match with 0-xV Controller	
Indoor LED Drivers	Outdoor LED Drivers
LUC-018SxxxDSP	ESC-075SxxxDT
LUC-024SxxxDSP	ESC-150SxxxDT
LUC-024SxxxDSW	ETC-150SxxxDT
EUC-026S045DS-0001	EUC-036SxxxDT/DV
EUC-026SxxxDS	EUC-052SxxxDT/DV
EUC-042SxxxDS-0001	EUC-075SxxxDD
EUC-042SxxxDS	EUC-075SxxxDT/DV
LUC-042DxxxDDM/DSM	EUC-100SxxxDT/DV
LUC-042S070DSP	EUC-108TxxxDT
LUC-042SxxxDSW	EUC-120SxxxDT/DV
LTC-040SxxxDSP	EUC-120TxxxDT/DV
LUC-042SxxxDTG	EUC-144QxxxDT
LUC-066TxxxDDM/DSM	EUC-150SxxxDDA
LUC-072QxxxDDM/DSM	EUC-150SxxxDTA/DVA
	EUC-160QxxxDT/DV
	EUC-180PxxxDT
	EUC-200PxxxDT/DV
	EUC-240HxxxDT/DV

Revision History

Change Date	Rev.	Description of Change		
		Item	From	To
2013-09-23	A	Datasheets Release	/	/
2013-11-19	B	Mechanical Outline	/	Updated
		Application Note	/	Added
2014-07-02	C	Dimensions	/	Added
		Net Weight	/	Added
		PC Interface of SDD-AAPNx and TDD-ANPNx	/	Added

Архангельск (8182)63-90-72
 Астана (7172)727-132
 Астрахань (8512)99-46-04
 Барнаул (3852)73-04-60
 Белгород (4722)40-23-64
 Брянск (4832)59-03-52
 Владивосток (423)249-28-31
 Волгоград (844)278-03-48
 Вологда (8172)26-41-59
 Воронеж (473)204-51-73
 Екатеринбург (343)384-55-89
 Иваново (4932)77-34-06

Ижевск (3412)26-03-58
 Иркутск (395)279-98-46
 Казань (843)206-01-48
 Калининград (4012)72-03-81
 Калуга (4842)92-23-67
 Кемерово (3842)65-04-62
 Киров (8332)68-02-04
 Краснодар (861)203-40-90
 Красноярск (391)204-63-61
 Курск (4712)77-13-04
 Липецк (4742)52-20-81
 Киргизия (996)312-96-26-47

Магнитогорск (3519)55-03-13
 Москва (495)268-04-70
 Мурманск (8152)59-64-93
 Набережные Челны (8552)20-53-41
 Нижний Новгород (831)429-08-12
 Новокузнецк (3843)20-46-81
 Новосибирск (383)227-86-73
 Омск (3812)21-46-40
 Орел (4862)44-53-42
 Оренбург (3532)37-68-04
 Пенза (8412)22-31-16
 Казахстан (772)734-952-31

Пермь (342)205-81-47
 Ростов-на-Дону (863)308-18-15
 Рязань (4912)46-61-64
 Самара (846)206-03-16
 Санкт-Петербург (812)309-46-40
 Саратов (845)249-38-78
 Севастополь (8692)22-31-93
 Симферополь (3652)67-13-56
 Смоленск (4812)29-41-54
 Сочи (862)225-72-31
 Ставрополь (8652)20-65-13
 Таджикистан (992)427-82-92-69

Сургут (3462)77-98-35
 Тверь (4822)63-31-35
 Томск (3822)98-41-53
 Тула (4872)74-02-29
 Тюмень (3452)66-21-18
 Ульяновск (8422)24-23-59
 Уфа (347)229-48-12
 Хабаровск (4212)92-98-04
 Челябинск (351)202-03-61
 Череповец (8202)49-02-64
 Ярославль (4852)69-52-93