

Features

- Programmable Dimming Control Scheme
- Three Timing Solutions
- Waterproof (IP66) and UL Dry / Damp Location



Description

The TDD-ANPNx Dimmer is designed to work with 0-10V dimmable LED driver. The standard features include programmable dimming control and factory setting.

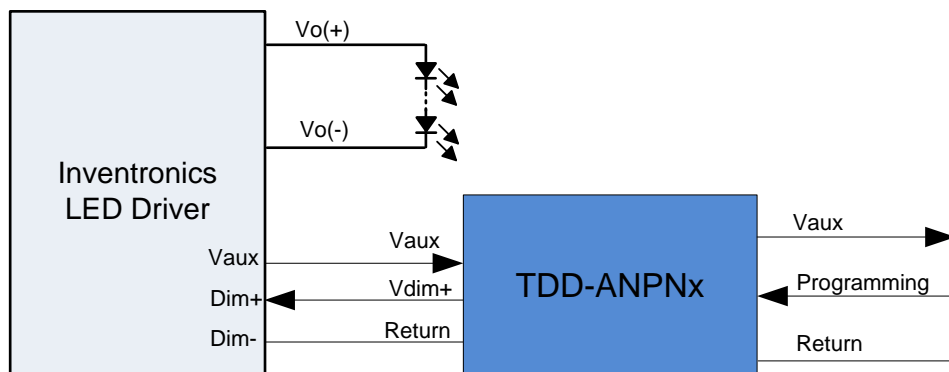

Models

Connection to LED driver	Connection to Control	Model Number
UL Wire(black/white, purple, gray) with flying leads	UL Wire(yellow, pink, gray) with flying leads	TDD-ANPN1 ⁽¹⁾
UL Wire with UL female connector	UL Wire(yellow, pink, gray) with flying leads	TDD-ANPN2 ⁽¹⁾
UL Wire with UL female connector	UL Wire with UL male connector	TDD-ANPN3 ⁽¹⁾
VDE Wire(black/white, purple, gray) with flying leads	VDE Wire(yellow, pink, gray) with flying leads	TDD-ANPN4 ⁽²⁾
VDE Wire with UL female connector	VDE Wire(yellow, pink, gray) with flying leads	TDD-ANPN5 ⁽²⁾
VDE Wire with UL female connector	VDE Wire with UL male connector	TDD-ANPN6 ⁽²⁾

Notes: (1) Certificates have got UL, FCC, CE.

(2) Certificates have got TUV, CE, CB, CQC.

Programmer Model

Name	Description	Model Number	Notes
Multi programmer	2 nd Generation Multiple Programmer	PRG-MUL2	Use this device to program TDD-ANPNx. Please check the details in the datasheet of PRG-MUL2.

Архангельск (8182)63-90-72
Астана (7172)727-132
Астрахань (8512)99-46-04
Барнаул (3852)73-04-60
Белгород (4722)40-23-64
Брянск (4832)59-03-52
Владивосток (423)249-28-31
Волгоград (844)278-03-48
Вологда (8172)26-41-59
Воронеж (473)204-51-73
Екатеринбург (343)384-55-89
Иваново (4932)77-34-06

Ижевск (3412)26-03-58
Иркутск (395)279-98-46
Казань (843)206-01-48
Калининград (4012)72-03-81
Калуга (4842)92-23-67
Кемерово (3842)65-04-62
Киров (8332)68-02-04
Краснодар (861)203-40-90
Красноярск (391)204-63-61
Курск (4712)77-13-04
Липецк (4742)52-20-81
Киргизия (996)312-96-26-47

Магнитогорск (3519)55-03-13
Москва (495)268-04-70
Мурманск (8152)59-64-93
Набережные Челны (8552)20-53-41
Нижний Новгород (831)429-08-12
Новокузнецк (3843)20-46-81
Новосибирск (383)227-86-73
Омск (3812)21-46-40
Орел (4862)44-53-42
Оренбург (3532)37-68-04
Пенза (8412)22-31-16
Казахстан (772)734-952-31

Пермь (342)205-81-47
Ростов-на-Дону (863)308-18-15
Рязань (4912)46-61-64
Самара (846)206-03-16
Санкт-Петербург (812)309-46-40
Саратов (845)249-38-78
Севастополь (8692)22-31-93
Симферополь (3652)67-13-56
Смоленск (4812)29-41-54
Сочи (862)225-72-31
Ставрополь (8652)20-65-13
Таджикистан (992)427-82-92-69

Сургут (3462)77-98-35
Тверь (4822)63-31-35
Томск (3822)98-41-53
Тула (4872)74-02-29
Тюмень (3452)66-21-18
Ульяновск (8422)24-23-59
Уфа (347)229-48-12
Хабаровск (4212)92-98-04
Челябинск (351)202-03-61
Череповец (8202)49-02-64
Ярославль (4852)69-52-93

Interface Specifications (TDD-ANPNx)

Parameter	Min.	Typ.	Max.	Notes
Vaux Voltage	10 V	12 V	13.2 V	
Vaux Current	-	-	20 mA	

Time Specifications

Parameter	Min.	Typ.	Max.	Notes
Time Tolerances	-2%	-	2%	
Temperature Coefficient	-	0.02%/°C	-	

General Specifications

Parameter	Min.	Typ.	Max.	Notes
Dimensions Inches (H x D) Millimeters (H x D)		1.5 x 0.63 38 x 16		
Net Weight	-	40 g	-	

Environmental Specifications

Parameter	Min.	Typ.	Max.	Notes
Operating Temperature	-40 °C	-	+70 °C	Humidity: 10% RH to 100% RH.
Storage Temperature	-40 °C	-	+70 °C	Humidity: 5% RH to 100% RH,

Safety & EMC Compliance

Safety Category	Standard
UL/CUL	UL8750,CAN/CSA-C22.2 No. 250.13
CE	EN 61347-1, EN61347-2-11
EMI Standards	Notes
EN 55015 ⁽¹⁾	Conducted emission Test & Radiated emission Test
FCC Part 15 ⁽¹⁾	ANSI C63.4 Class B This device complies with Part 15 of the FCC Rules. Operation is subject to the following two conditions: [1] this device may not cause harmful interference, and [2] this device must accept any interference received, including interference that may cause undesired operation.

Safety & EMC Compliance(Continued)

EMS Standards	Notes
EN 61547	Electromagnetic Immunity Requirements Applies To Lighting Equipment

Note: (1)The TDD-ANPNx is considered as a component that will be operated in combination with final equipment. Since EMI performance will be affected by the complete installation, the final equipment manufacturers must requalify EMI Directive on the complete installation again.

Mechanical Outline

TDD-ANPN1

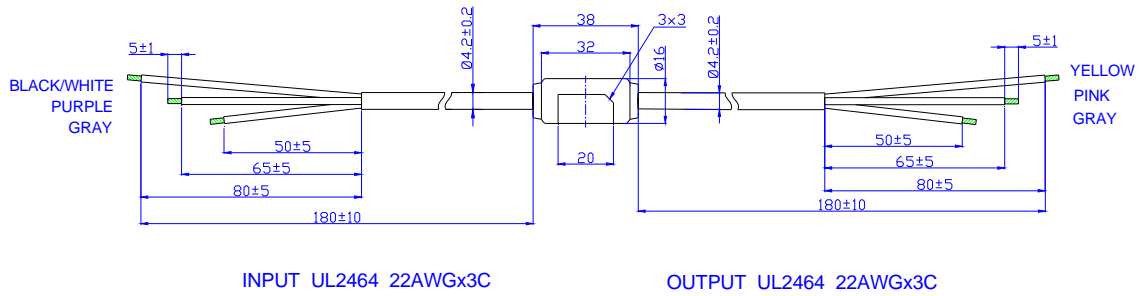

TDD-ANPN2

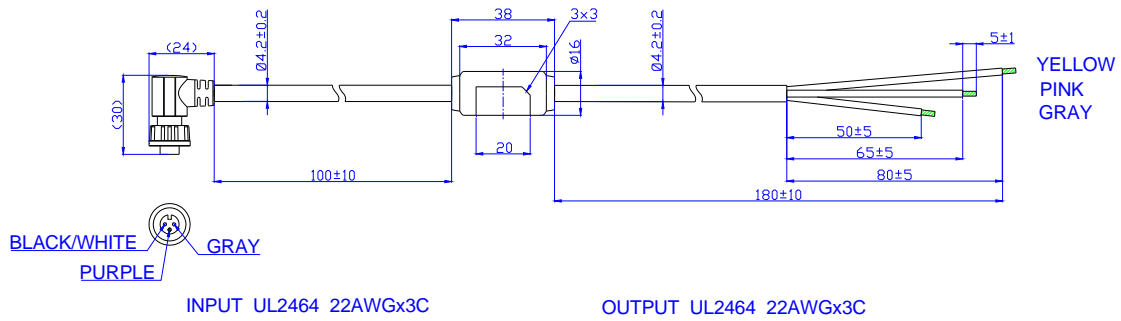

TDD-ANPN3

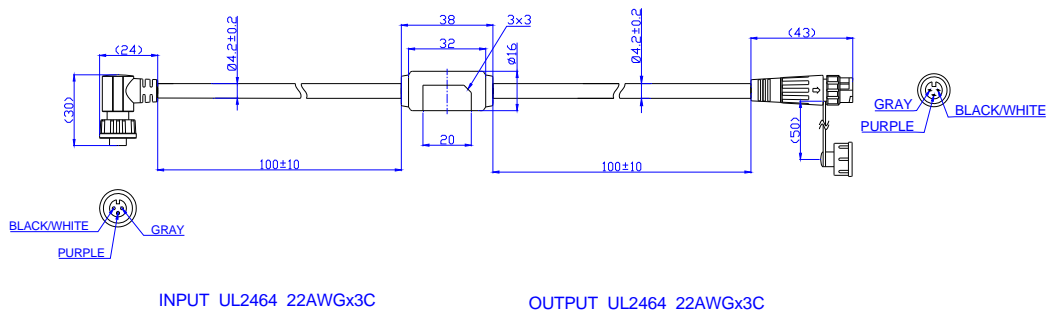

TDD-ANPN4

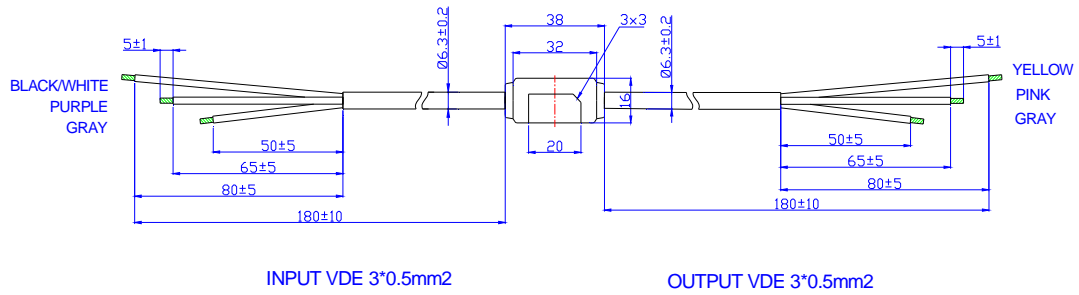

TDD-ANPN5

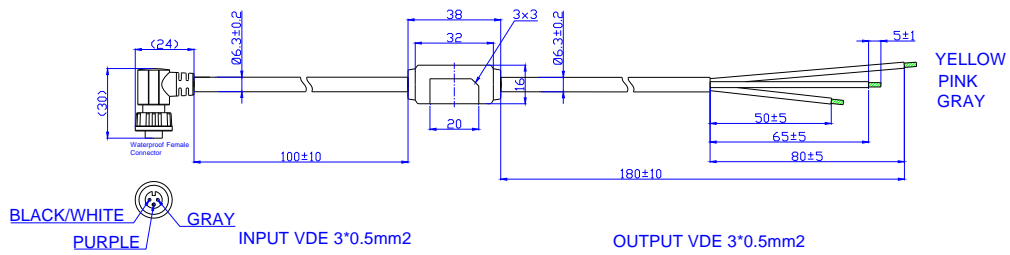

TDD-ANPN6

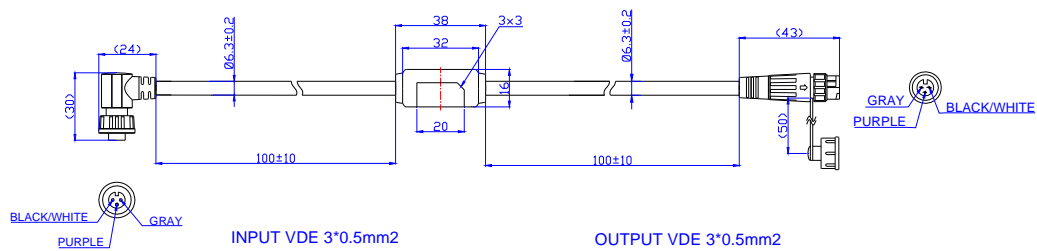

Function definition of interface

Connection to LED driver			Connection to Control		
Wire Color	Function	Connection	Wire Color	Function	Connection
BLACK/WHITE	Vaux	To LED driver's auxiliary power	YELLOW (BLACK/WHITE)	Vaux	Auxiliary Power for external circuit
PURPLE	Vdim+	To LED driver's dimming	PINK(PURPLE)	Programming	Programming input
GRAY	Return	Return for auxiliary power and dimming signal	GRAY	Return	Return for auxiliary power and dimming signal

Programming Setup

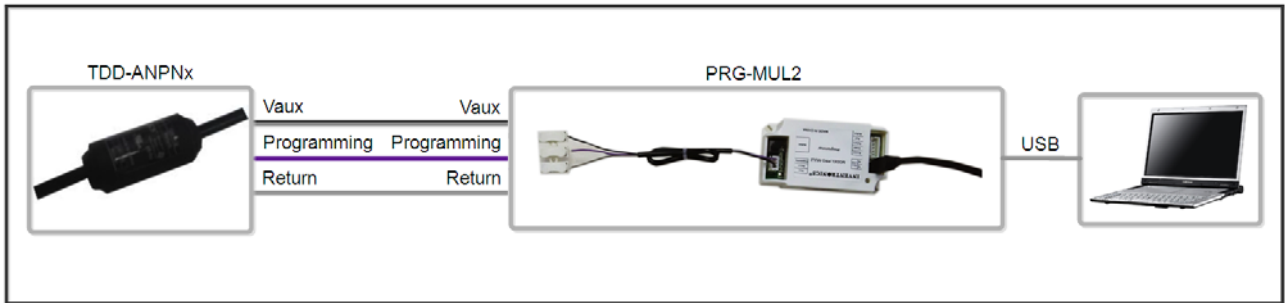

Default Configuration

Programming Application Note

1. Introduction of the key words in the software

Item	Name	Description	Note
1	Slider	Set timing curve – Load, holding time and fade time, no more than 6 segments can be set	
2	Language	Shift the language between Chinese and English	
3	Write CFG	Save the user setting configuration file to PC	
4	Read CFG	Load the user setting configuration file from PC	
5	Default	Default configuration	

Programming Application Note (Continued)

Item	Name	Description	Note
6	Read Driver	Read timer setting configuration from timer to PC	
7	Write to Driver	Write timer setting configuration from PC to timer	
8	Dimming Mode	<ol style="list-style-type: none"> 1. Self adapt-Midnight: Automatically adjust the dimming curve based on the on-time of past two days (difference<15 minutes), assuming that the center point of the dimming curve is the mid night local time. 2. Self adapt-Percentage: Automatically adjust the on-time with constant percentage no matter how long the on-time is. (Zoom in or Zoom out the time for each duration proportioned to initial time and valid on-time), also according to the on-time of past two days (difference<15 minutes) 3. Traditional timer: Follow up with the set timing curve after power on without the automatically change 	
9	Driver series	Select the LED driver series, then set driver model.	
10	Driver model	Select the driver model.	
11	Total time	Initial on-time setting for the two self-adaptive modes	
12	Midnight	Set the midnight point as a start reference	For self adapt-midnight mode only
13	Initial Dim	Set initial dimming level before running the curve	This is for the software write verification.
14	Initial Hold	Set the hold time for Initial dimming level	
15	Curve	Display the timing curve	

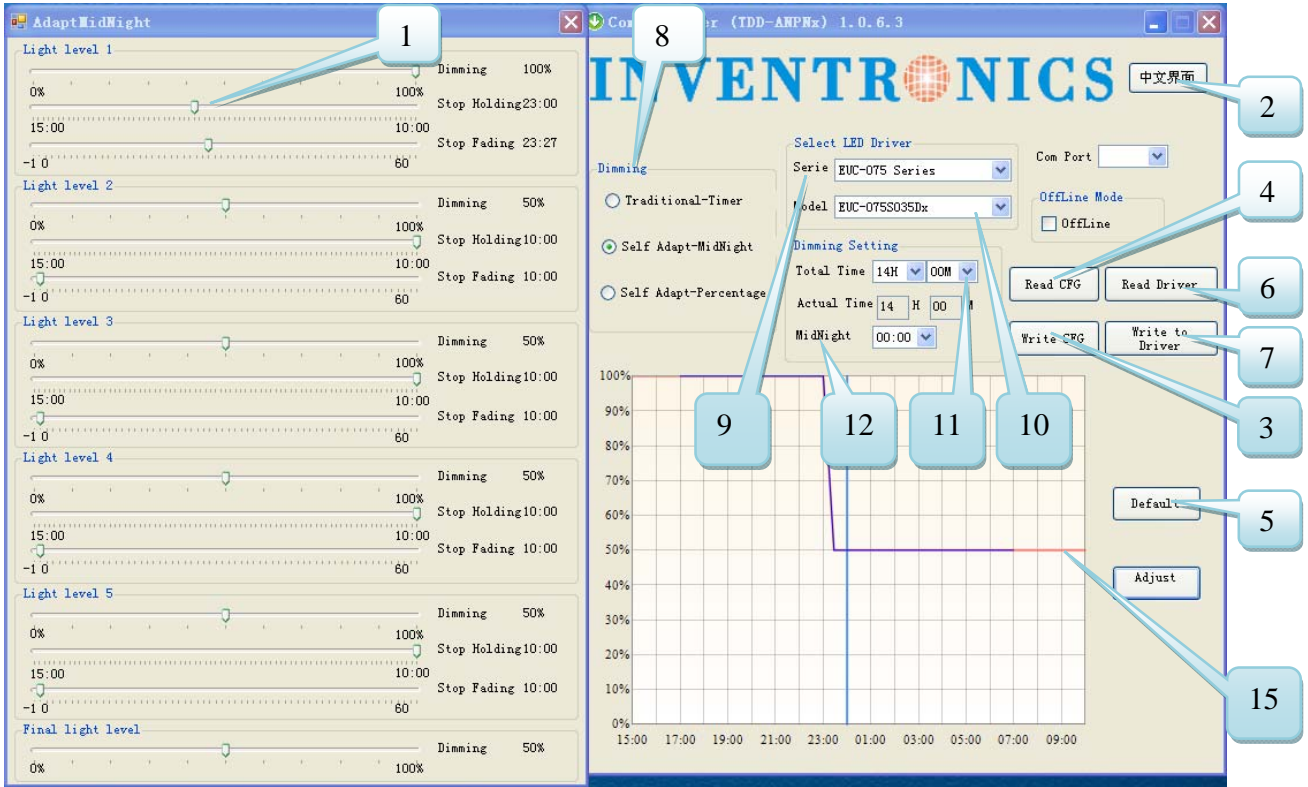

2. Software Installation and Programming

- 2.1 Download the Inventronics Software Package from website as below:
http://www.inventronics-co.com/download.aspx?c_kind=3&c_kind2=17&c_kind3=154
- 2.2 Install the setup file in the package to PC together the USB driver inside.
- 2.3 Connector PC, programmer, timer and the driver as below:

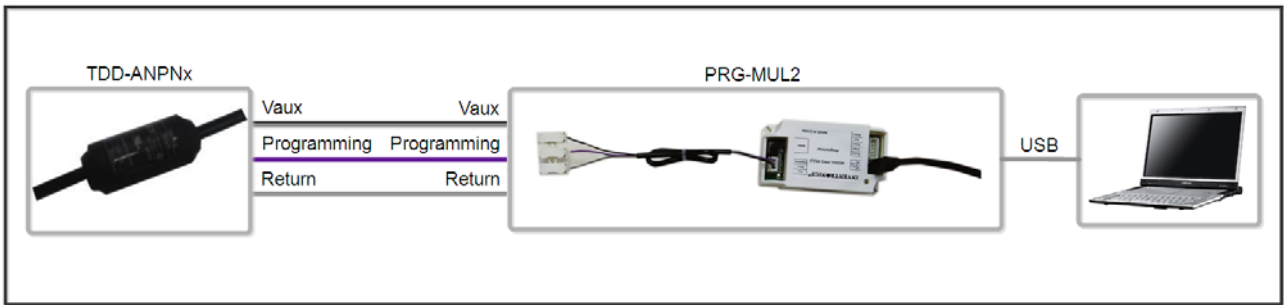

- 2.4 Start the software.
- 2.5 Input the information needed for programming.
- 2.6 Save the configuration as file if needed.
- 2.7 Write the configuration to products.
- 2.8 Switch to set the next timer and driver if needed.
- 2.9 Repeat 2.7~2.8 if needed.
- 2.10 Close software.
- 2.11 Disconnect PC, programmer, timer and the driver

Note: 2.5 can be replaced by "Read CFG" if the configuration is existing.

3. Programming Examples

3.1 Self adapt-Midnight

3.2 Initial state at 100% load, then 23:00 to 50% load, fade time 30 minutes; initial on-time:10H; LED driver: EUC-075S035DT; Midnight at 0:00 local time. The configuration is as below:

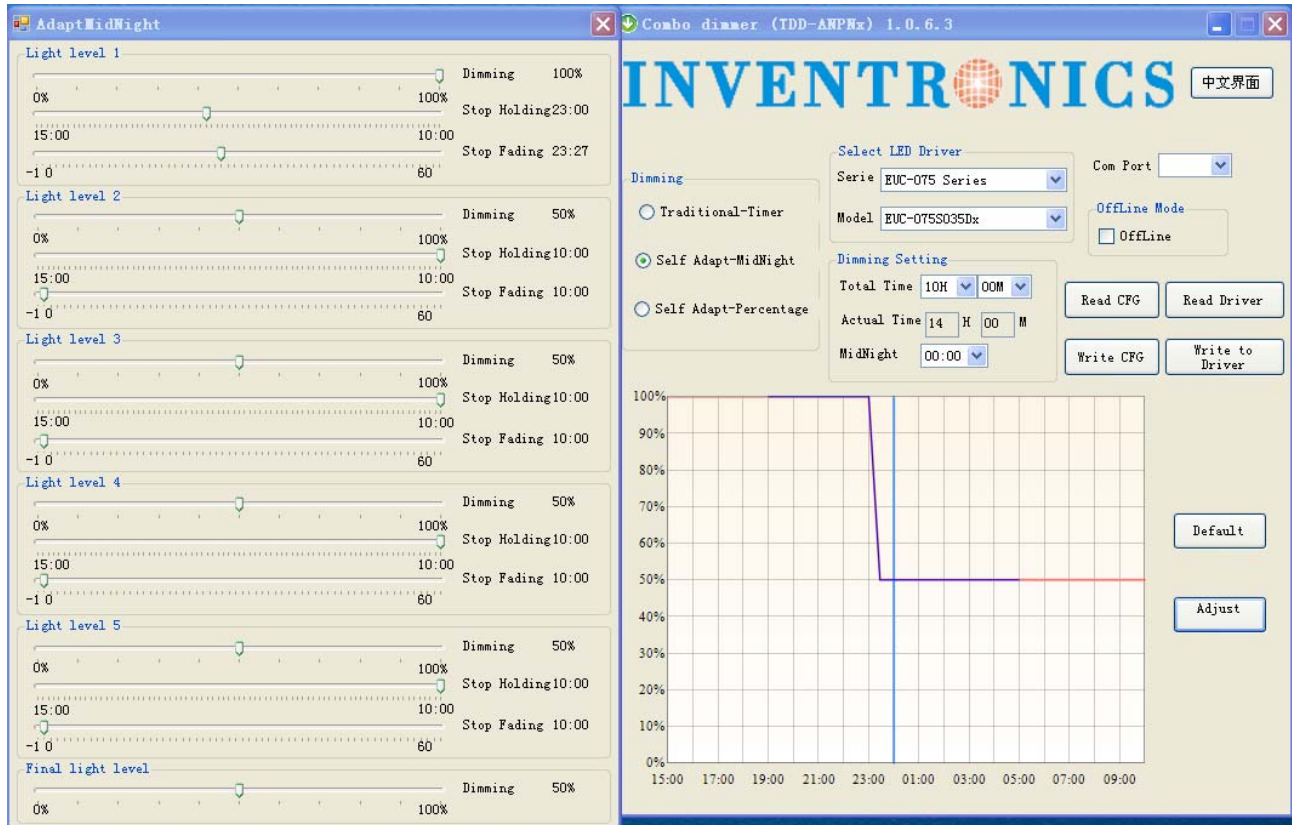

The purple wire is on-time (if 19:00 power on and 5:00 power off, suppose this as summer).

In autumn or spring, the on-time should be longer, suppose 18:00 power on and 6:00 power off, the curve will be self adjust to blue wire in following picture. The transition time is same at 23:00.

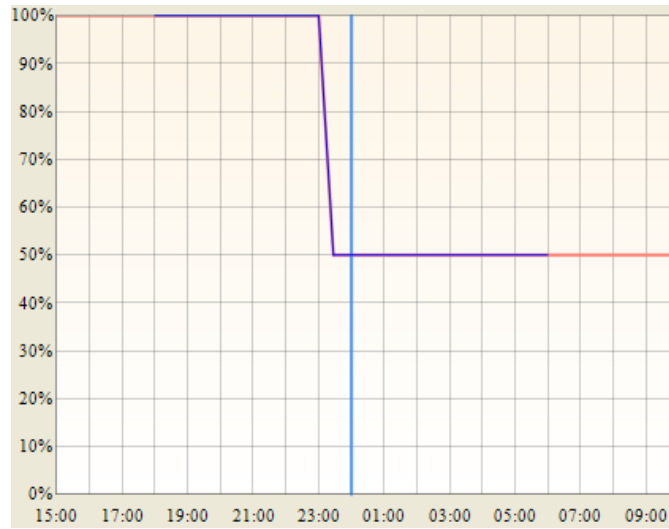

In winter the on-time should be longest, suppose 17:00 power on and 7:00 power off, the curve will be self adjust to blue wire in following picture. The transition time is same at 23:00.

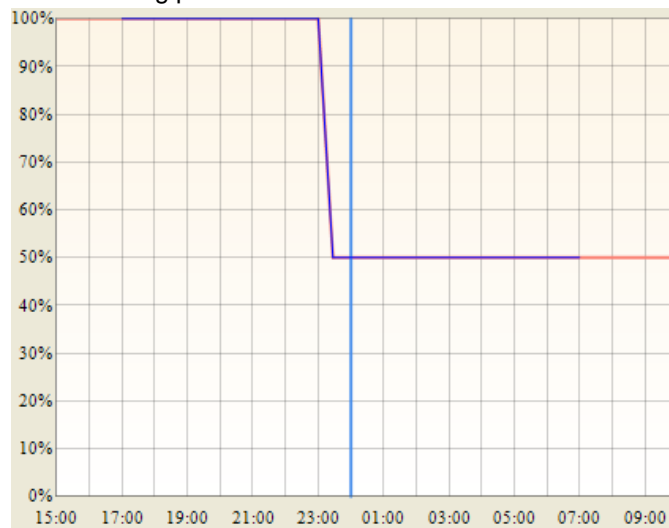

3.3 Self adapt-Percentage

50% time for 100% load, 10% time to 50% load and then keep; initial on-time: 10H; LED drive: EUC-075S035DT. The configuration is as below:

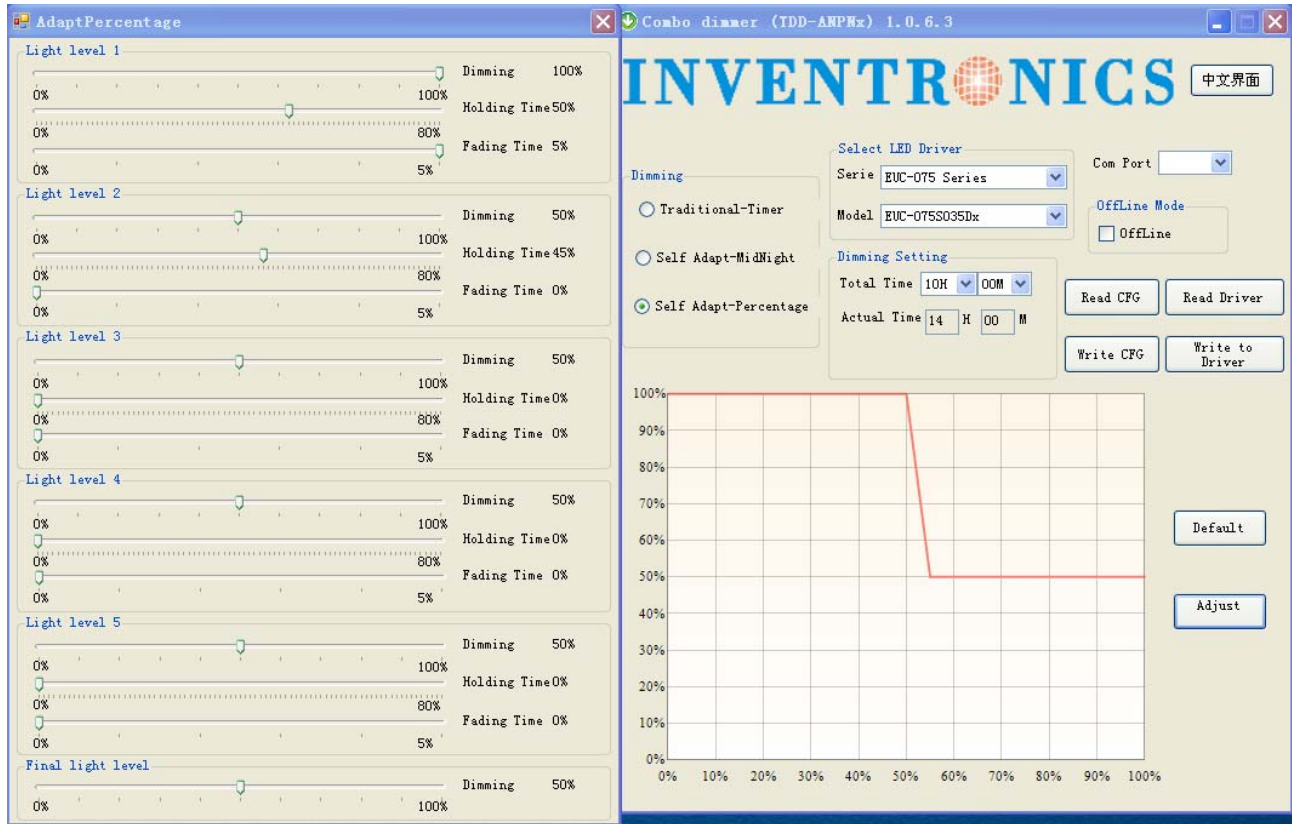

If total on-time is 10Hours, the time for 100% load is 5Hours, transition time is 1Hours, the time for 50% load is 4Hours;

If total on-time is changed to 14Hours, the time for 100% load is 7Hours, transition time is 1.4Hours, the time for 50% load is 5.6Hours;

If total on-time is changed to 8Hours, the time for 100% load is 4Hours, transition time is 0.8Hours, the time for 50% load is 3.2Hours

3.4 Traditional timer

100% load for 7Hours, fade time 30 minutes to 50% load, 3S with 50% load before run curve; LED drive: EUC-075S035DT. The configuration is as below:

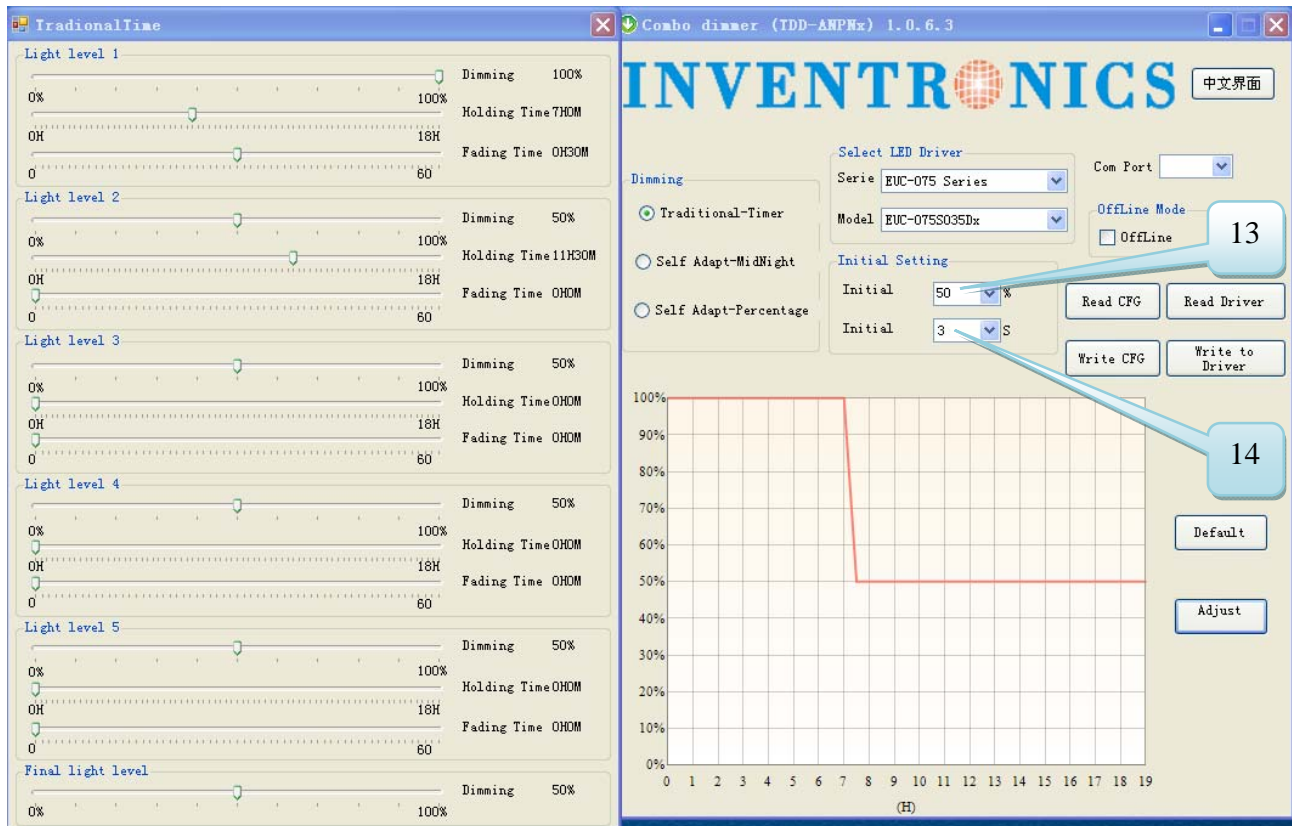

Application Note

This Timer controller can only work with 0-10V Dimmable LED drivers. Below is the list:

LED Series Can Match with Timer Controller	
Indoor LED Drivers	Outdoor LED Drivers
LUC-018SxxxDSP	ESC-075SxxxDT
LUC-024SxxxDSP	ESC-150SxxxDT
LUC-024SxxxDSW	ETC-150SxxxDT
EUC-026S045DS-0001	EUC-036SxxxDT/DV
EUC-026SxxxDS	EUC-052SxxxDT/DV
EUC-042SxxxDS-0001	EUC-075SxxxDD
EUC-042SxxxDS	EUC-075SxxxDT/DV
LUC-042DxxxDDM/DSM	EUC-100SxxxDT/DV
LUC-042S070DSP	EUC-108TxxxDT
LUC-042SxxxDSW	EUC-120SxxxDT/DV
LTC-040SxxxDSP	EUC-120TxxxDT/DV
LUC-042SxxxDTG	EUC-144QxxxDT

Application Note (Continued)

LED Series Can Match with Timer Controller	
Indoor LED Drivers	Outdoor LED Drivers
LUC-066TxxxDDM/DSM	EUC-150SxxxDDA
LUC-072QxxxDDM/DSM	EUC-150SxxxDTA/DVA
	EUC-160QxxxDT/DV
	EUC-180PxxxDT
	EUC-200PxxxDT/DV
	EUC-240HxxxDT/DV

RoHS Compliance

Our products comply with the European Directive 2011/65/EC, calling for the elimination of lead and other hazardous substances from electronic products.

Revision History

Change Date	Rev.	Description of Change		
		Item	From	To
2013-09-23	A	Datasheet Release	/	/
2013-11-19	B	Mechanical Outline	/	Updated
		Application Note	/	Added
2014-07-14	C	Default Configuration	/	Added
		Net weight	/	Added
		Dimensions	/	Added
2018-02-07	D	Features	/	Updated
		Description	/	Updated
		Programmer Model	/	Updated
		Function definition of interface	/	Updated
		Programming Setup - programming connection diagram	/	Updated
		Default Configuration	/	Updated
		Programming Application Note - PWM and programmable step dimming	/	Deleted

Архангельск (8182)63-90-72
 Астана (7172)727-132
 Астрахань (8512)99-46-04
 Барнаул (3852)73-04-60
 Белгород (4722)40-23-64
 Брянск (4832)59-03-52
 Владивосток (423)249-28-31
 Волгоград (844)278-03-48
 Вологда (8172)26-41-59
 Воронеж (473)204-51-73
 Екатеринбург (343)384-55-89
 Иваново (4932)77-34-06

Ижевск (3412)26-03-58
 Иркутск (395)279-98-46
 Казань (843)206-01-48
 Калининград (4012)72-03-81
 Калуга (4842)92-23-67
 Кемерово (3842)65-04-62
 Киров (8332)68-02-04
 Краснодар (861)203-40-90
 Красноярск (391)204-63-61
 Курск (4712)77-13-04
 Липецк (4742)52-20-81
 Киргизия (996)312-96-26-47

Магнитогорск (3519)55-03-13
 Москва (495)268-04-70
 Мурманск (8152)59-64-93
 Набережные Челны (8552)20-53-41
 Нижний Новгород (831)429-08-12
 Новокузнецк (3843)20-46-81
 Новосибирск (383)227-86-73
 Омск (3812)21-46-40
 Орел (4862)44-53-42
 Оренбург (3532)37-68-04
 Пенза (8412)22-31-16
 Казахстан (772)734-952-31

Пермь (342)205-81-47
 Ростов-на-Дону (863)308-18-15
 Рязань (4912)46-61-64
 Самара (846)206-03-16
 Санкт-Петербург (812)309-46-40
 Саратов (845)249-38-78
 Севастополь (8692)22-31-93
 Симферополь (3652)67-13-56
 Смоленск (4812)29-41-54
 Сочи (862)225-72-31
 Ставрополь (8652)20-65-13
 Таджикистан (992)427-82-92-69

Сургут (3462)77-98-35
 Тверь (4822)63-31-35
 Томск (3822)98-41-53
 Тула (4872)74-02-29
 Тюмень (3452)66-21-18
 Ульяновск (8422)24-23-59
 Уфа (347)229-48-12
 Хабаровск (4212)92-98-04
 Челябинск (351)202-03-61
 Череповец (8202)49-02-64
 Ярославль (4852)69-52-93

<http://inventronics.nt-rt.ru/> || ncs@nt-rt.ru