

Features

- Programmable Dimming Control
- 0-10V dimming voltage output
- Programmable Soft Start
- Output Lumen Compensation
- Thermal Protection
- Daylight Harvesting
- Remote Control
- Programmable via PC interface



Description

This is a programmable Control Signal Integrating Module (CSIM). This module is designed to integrate multiple signals (Dimmer, Occupancy Sensor, Ambient Light Sensor, RNTC, Remote control, Output Lumen Compensation, etc) into a 0-10V analog output and a 5V PWM output. The internal parameters can be programmed by user via PC interface and programmer.

Models

P/N(1)	Description
CDD-CNPN	Programmable CSIM with Default setting
CDD-CNPNP	CSIM Programmer

Note: (1) A suffix –xxxx may be added to denote variations or modifications to the base product, where x can be any alphanumeric character or blank

Pin Configurations

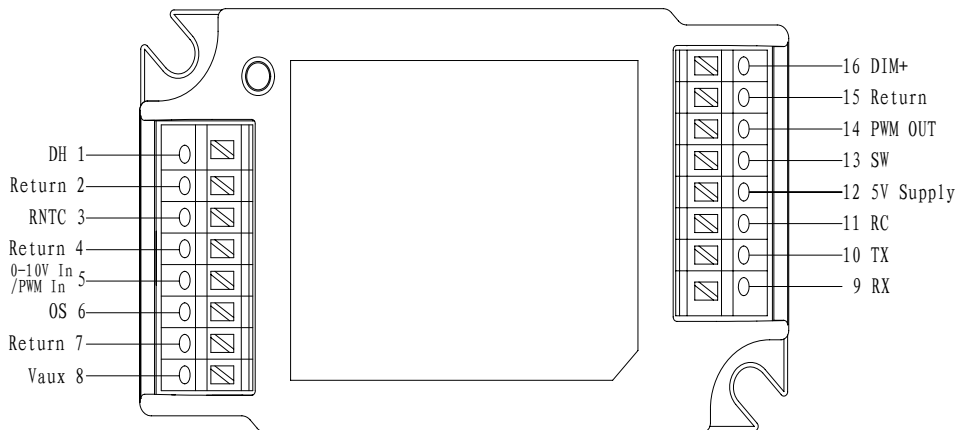

- | | | | | |
|------------------------------------|-----------------------------------|--|---------------------------------------|---------------------------------|
| Архангельск (8182)63-90-72 | Ижевск (3412)26-03-58 | Магнитогорск (3519)55-03-13 | Пермь (342)205-81-47 | Сургут (3462)77-98-35 |
| Астана (7172)727-132 | Иркутск (395)279-98-46 | Москва (495)268-04-70 | Ростов-на-Дону (863)308-18-15 | Тверь (4822)63-31-35 |
| Астрахань (8512)99-46-04 | Казань (843)206-01-48 | Мурманск (8152)59-64-93 | Рязань (4912)46-61-64 | Томск (3822)98-41-53 |
| Барнаул (3852)73-04-60 | Калининград (4012)72-03-81 | Набережные Челны (8552)20-53-41 | Самара (846)206-03-16 | Тула (4872)74-02-29 |
| Белгород (4722)40-23-64 | Калуга (4842)92-23-67 | Нижний Новгород (831)429-08-12 | Санкт-Петербург (812)309-46-40 | Тюмень (3452)66-21-18 |
| Брянск (4832)59-03-52 | Кемерово (3842)65-04-62 | Новокузнецк (3843)20-46-81 | Саратов (845)249-38-78 | Ульяновск (8422)24-23-59 |
| Владивосток (423)249-28-31 | Киров (8332)68-02-04 | Новосибирск (383)227-86-73 | Севастополь (8692)22-31-93 | Уфа (347)229-48-12 |
| Волгоград (844)278-03-48 | Краснодар (861)203-40-90 | Омск (3812)21-46-40 | Симферополь (3652)67-13-56 | Хабаровск (4212)92-98-04 |
| Вологда (8172)26-41-59 | Красноярск (391)204-63-61 | Орел (4862)44-53-42 | Смоленск (4812)29-41-54 | Челябинск (351)202-03-61 |
| Воронеж (473)204-51-73 | Курск (4712)77-13-04 | Оренбург (3532)37-68-04 | Сочи (862)225-72-31 | Череповец (8202)49-02-64 |
| Екатеринбург (343)384-55-89 | Липецк (4742)52-20-81 | Пенза (8412)22-31-16 | Ставрополь (8652)20-65-13 | Ярославль (4852)69-52-93 |
| Иваново (4932)77-34-06 | Киргизия (996)312-96-26-47 | Казахстан (772)734-952-31 | Таджикистан (992)427-82-92-69 | |

Pin Description

Wire number	Name	Input /Output	Function
1	DH	Input	Daylight Harvesting Sensor to this pin
2,4,7,15	Return		Return for auxiliary power and signal
3	RNTC	Input	Temperature protection, connect a RNTC from this pin to GND
5	0-10V In /PWM In	Input	0-10V analog dimming signal input or PWM dimming signal input
6	OS	Input	Occupancy Sensor, connect the sensor output to this pin
8	Vaux	Input	Auxiliary power supply for this controller
9	RX	Input	Programming interface-Receive
10	TX	Output	Programming interface-Transmit
11	RC	Input	Remote Control, connect the receiver to this pin
12	5V Supply	Input/Output	5V input for programming/5V auxiliary output
13	SW	Output	System disable Output
14	PWM out	Output	PWM output for dimming
16	DIM+	Output	Provide 0-10V dimming control signal

Note: The reference of all signals is Return.

Function of 5-bit Jumper JP1

JP1	Short	Open	Default Setting
Bit 1	Enable PWM Dimming (0-10V dimming is disabled)	Enable 0-10V Dimming (PWM dimming is disabled)	Open
Bit 2	Enable Lumen Compensation	Disable Lumen Compensation and clear working Time	
Bit 3	Set maximum output level, see application for details		
Bit 4			
Bit 5	Enable Timing Profile	Disable Timing Profile	

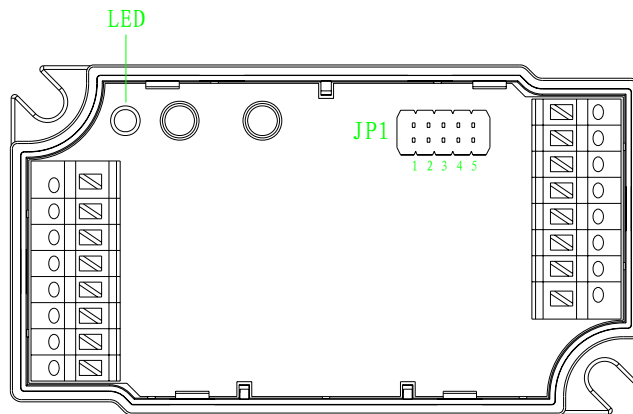

Input Specifications

Parameter	Min.	Typ.	Max.	Note
Vaux Voltage	11.4V	12V	25V	
Vaux Current	-	-	20mA	
0-10V In voltage	-0.3V	-	12V	
PWM High Range	4.5V	-	10V	
PWM Frequency Range	500Hz	-	2KHz	
RC voltage	-0.3V	-	5.5V	
DH voltage	-0.3V	-	12V	
OS voltage	-0.3V	-	12V	
RX	-0.3V	-	5.5V	

Output Specifications

Parameter	Min.	Typ.	Max.	Notes
DIM+ Voltage	0V	-	10V	
DIM+ Source Current	0mA	-	5mA	
DIM+ Sink Current	0mA	-	10mA	
PWM output/SW voltage high level	4V	-	5.5V	
PWM output/SW voltage Low level	-0.3V	-	0.8V	
PWM output/SW source current	0mA	-	5mA	
PWM Output Frequency	930Hz	980Hz	1030Hz	
5V Supply	4.5V	-	5.2V	In series with 100 ohm resistor inside, The output voltage is related to the current.
5V Supply Current	-5mA	-	5mA	
TX	-0.3V	-	5.5V	

Application Introduction

- System connection

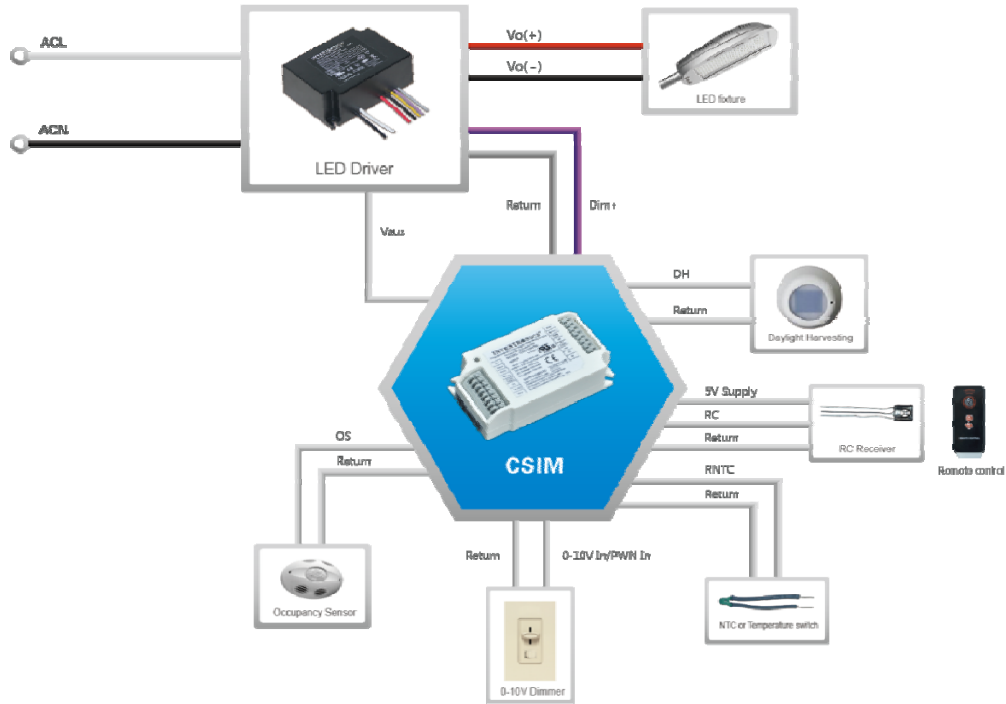

An external auxiliary power supply also can be used to power CSIM and other sensors if LED driver cannot provide auxiliary power.

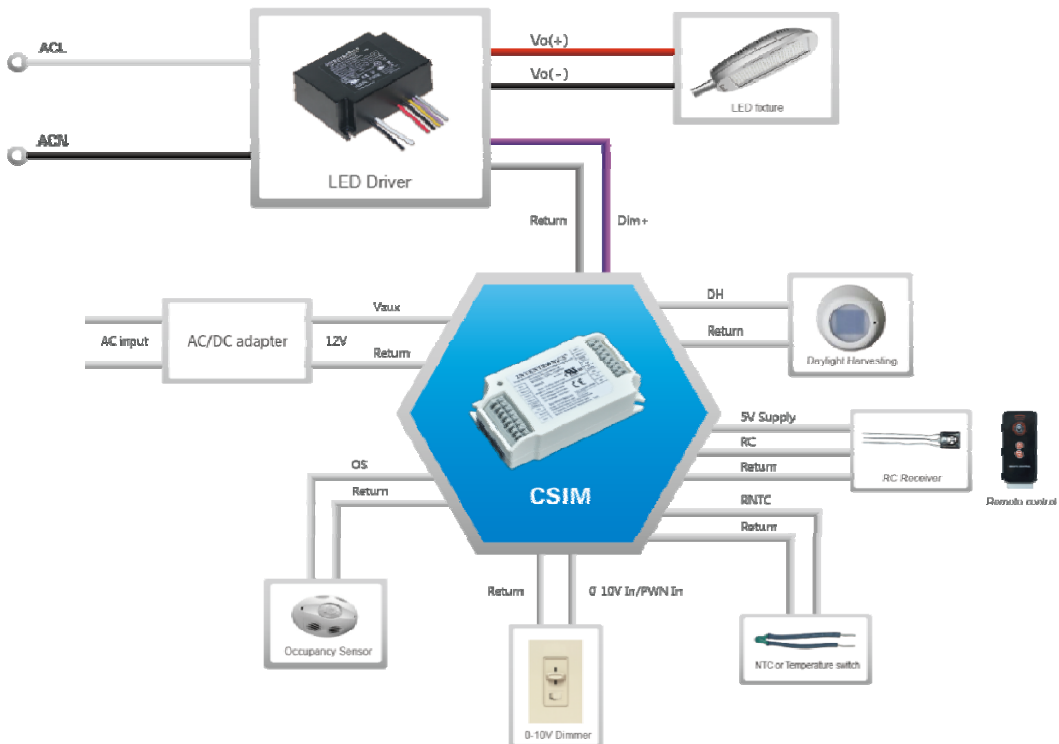

● **Output Lumen Compensation**

This controller has a built-in output Lumen compensation function. The lumen output of LEDs will decrease over their life. Thus the controller can set output current at 80% and over a time period defined by the LED manufacturers specification increase the output current to 100% compensating for lumen degradation. The initial output and compensation can be programmed and this function can be disabled via factory setting. The default setup is as following:

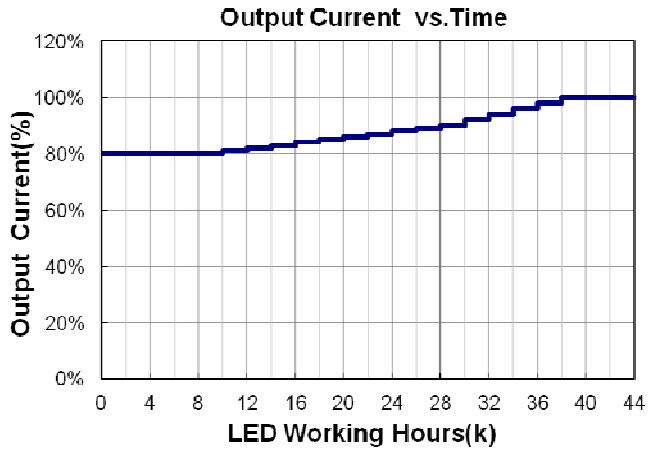
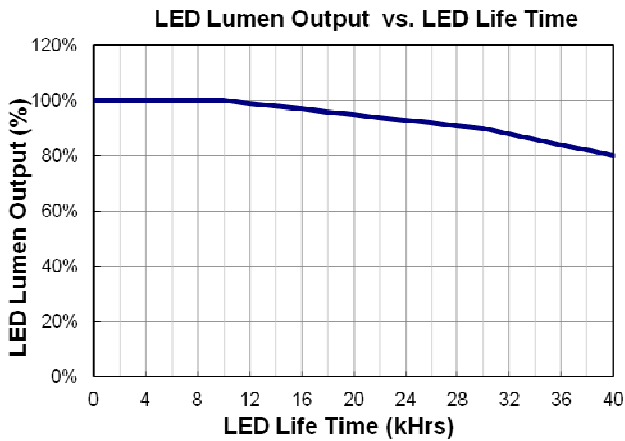

Output Current (%)	80%	81%	82%	83%	84%	85%	86%	87%
LED working time (kHours)	8	10	12	14	16	18	20	22
Output Current (%)	88%	89%	90%	92%	94%	96%	98%	100%
LED working time (kHours)	24	26	28	30	32	34	36	38

This function is by default disabled and can be enabled via switch (JP1 Bit2 to ON location).

● **Temperature Protection**

When using the RNTC to monitor the temperature of a LED module or driver, if the RNTC value is less than the RNTC threshold, the output current will be decreased by the desired value. After the RNTC value rises above the RNTC threshold, the temperature protection is removed and output current will return to normal.

When using one controller to monitor multiple lighting fixtures, it is recommended to use one thermal switch for each fixture and connect the switches to this pin in parallel. When any one switch falls below falls below 3K, the controller will dim all connected fixtures, recovering to normal output current after the fault is removed.

Recommended product type: RNTC or normal open thermal switch

● **Soft-start**

The controller can soft-start current to the LED. The rise time can be programmed via factory settings. The default value is 1S.

● **Set Maximum output voltage and Duty cycle**

The maximum output voltage and duty cycle can be set via 2-bit switch. Default setting is OFF

JP1 Bit3	JP1 Bit4	Maximum output voltage on Dim+	Maximum duty cycle on PWM output
OFF	OFF	10V	100%
OFF	ON	9V	90%
ON	OFF	8V	80%
ON	ON	7V	70%

● **Occupancy sensor**

Connecting the output of occupancy sensor to the OS pin of this controller allows for the recognition of movement within an area, causing all connected lights to be brought up automatically. Once movement is no longer detected, and after the delay time has elapsed, the dimmer will return to its previous state.

Recommended product type: Occupancy: High level, No occupancy: Low level. Sensor Switch: RM PDT 9

● **0-10V input dimming/PWM input dimming**

This controller can combine dimming input (either 0-10V or PWM) with other functions (Output lumen compensation, temperature protection, soft-start, RSET to set output current), before outputting an adjusted dimming signal. Default dimming input is 0-10V but can be changed to PWM dimming via factory setting or setting JP1 Bit1 to ON location.

● **Remote control**

This controller uses the NEC 6122 protocol for IR remote control. It consists of a Lead code, 8 bit customer code, 8 bit customer complement code, 8 bit data code, 8 bit data complement code.

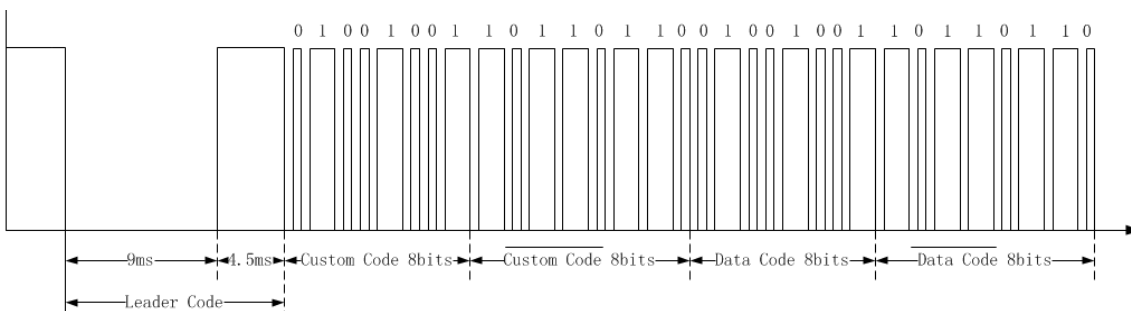

Logic 0 and 1 are shown as below:

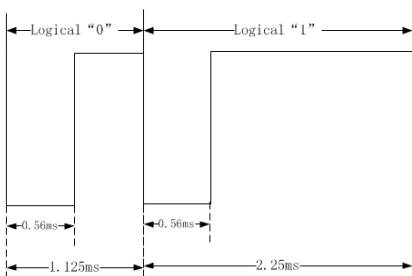

Repeat code is shown as below:



Default value for control:

Turn on or off: 0x05

Dimming Up: 0x0D

Dimming Down: 0x11

Note: The waveform is the output of IR receiver, not the carrier waveform.

- **Daylight Harvesting**

This controller can receive daylight sensor signal and output a dimming signal to keep lumens constant.

Recommended product type: Sensor Switch CM-ADC

Note: The valid input range is 0-9V for daylight sensor; otherwise, the function is invalid.

- **Timing Profile**

This controller has built-in timing profiles. Default is disabled. Connect JP1 Bit5 to ON location to select timing profile. The priority of this function is lowest. The default profile is as following:

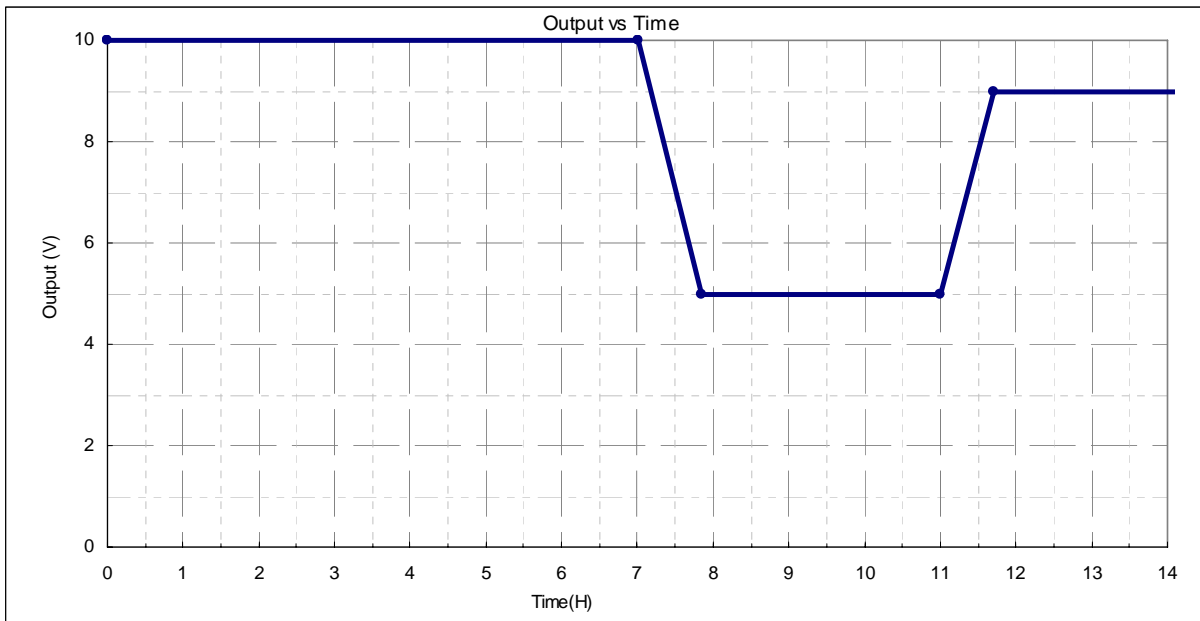

- **0-10V output dimming**

This controller can output a 0-10V analog dimming signal.

- **PWM output dimming**

This controller can output a PWM dimming signal.

- **System disable signal output**

This controller can output a disable signal for some commands, such as occupancy sensor or low dimming voltage (Dim+ <1V). The output is low under normal conditions, and set to high when disable signal is active. Customer can use this signal to control line switch via relay, or other control circuit, to shut down the LED driver completely. In this situation the CSIM must be independently powered (not connected to the Driver's auxiliary output).

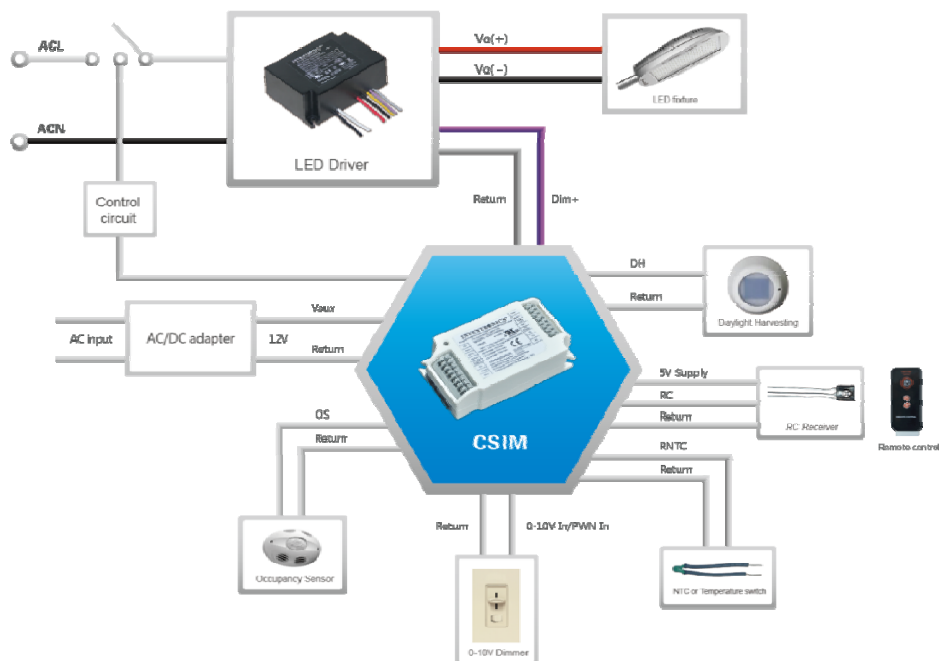

● **LED indicator**

The LED indicator indicates the working status of this controller;

Green: Working normally;

Red: Fault such as Power Down

Red Slowly Blinking: Fault such as temperature protection

Orange: Under IR Remote Control

Green Blinking Quickly: Communication

● **Programming**

The internal parameters can be set via a PC interface programmed by the user. The internal parameters can also be read out to be displayed on the PC interface. The programming sequence requires the program-verify-feedback, so in programming mode, TX and RX should be connected correctly, and only one UUT can be programmed at a time.

The Following parameters can be programmed:

Lumen compensation – load and time;

Time profile – load and time

0-10V/PWM select;

ON/OFF for all functions

Maximum value set;

Software set;

Delay time;

RNTC threshold;

Key value of IR remote control;

● Programmer connection

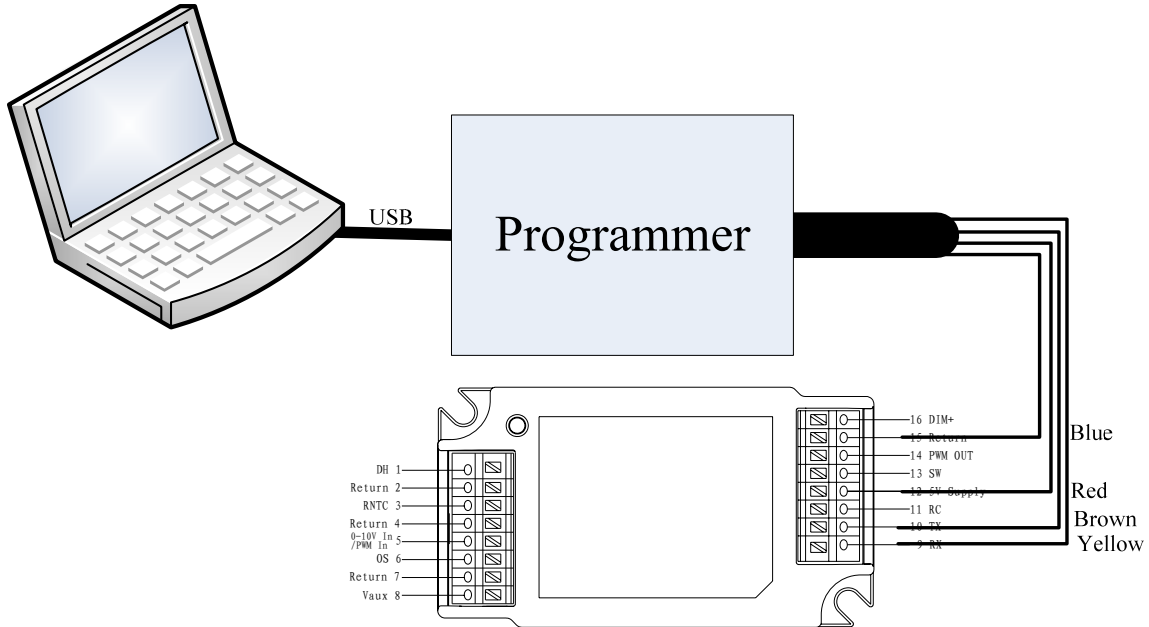

Wire Color	CSIM's Pin
Blue	Return
Red	5V Supply
Brown	TX
Yellow	RX

Note: 1. Disconnect all other connections except the 4 connections described above when programming CSIM

2. Disconnect Red (5V Supply) if CSIM is powered by an external power supply.

● PC interface

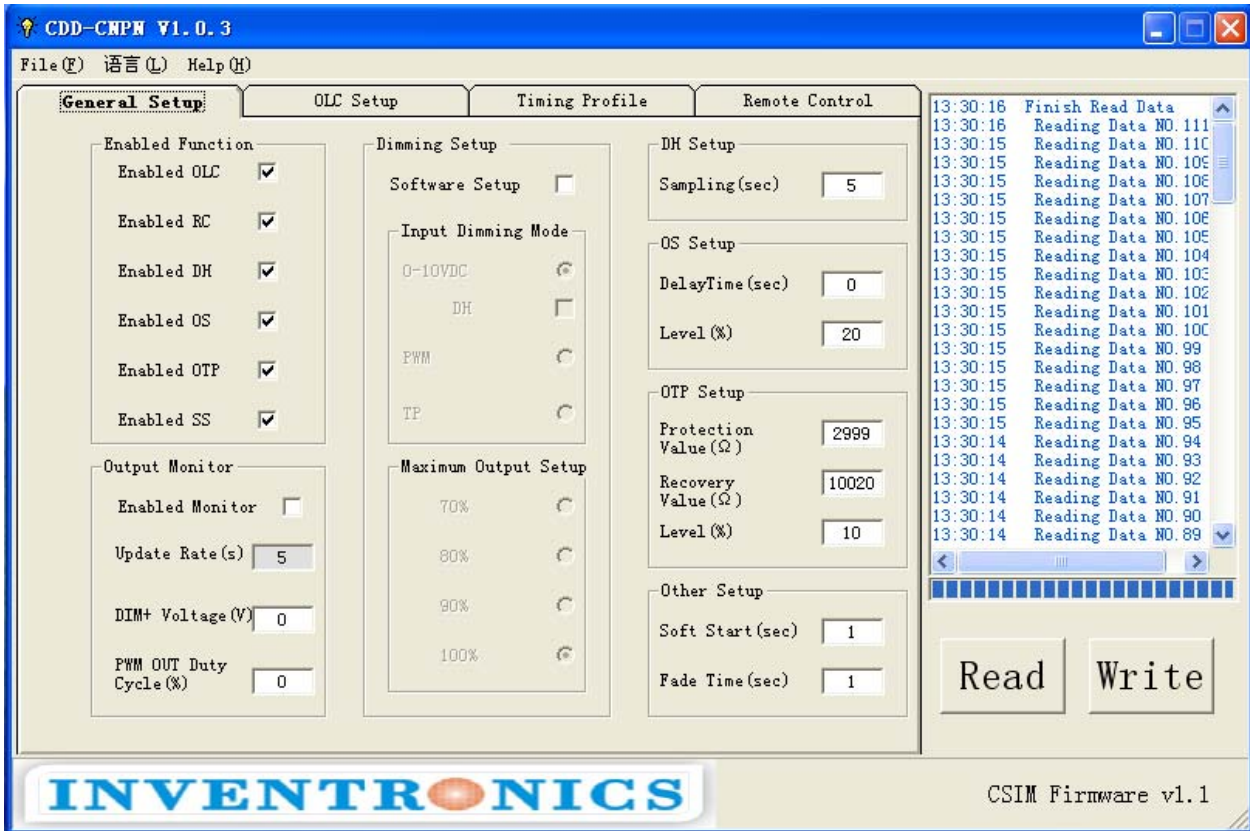

General Specifications

Parameter	Min.	Typ.	Max.	Notes
Dimensions Inches (L x W x H) Millimeters (L x W x H)		3.35 x 1.85 x 0.83 85 x 47 x 21		
Net Weight	-	45 g	-	

Note: All specifications are typical at 25 °C unless otherwise stated.

Environmental Specifications

Parameter	Min.	Typ.	Max.	Notes
Operating Temperature	-20°C	-	+70 °C	Humidity: 10% RH to 100% RH
Storage Temperature	-20 °C	-	+85 °C	Humidity: 5% RH to 100% RH

Mechanical Outline

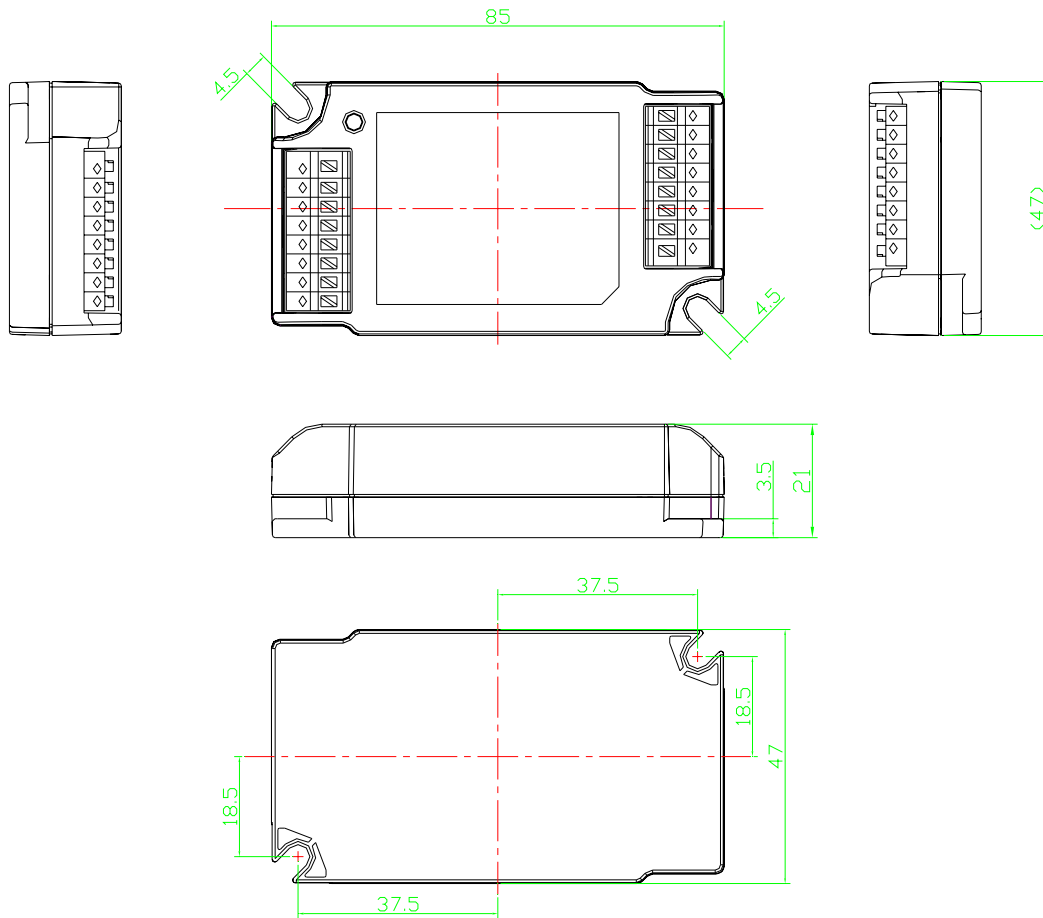

RoHS Compliance

Our products comply with the European Directive 2011/65/EC, calling for the elimination of lead and other hazardous substances from electronic products.

Revision History

Change Date	Rev.	Description of Change		
		Item	From	To
2013-04-17	A	Datasheets Release	/	/
2014-06-26	B	Product dimensions	/	Added
		Net weight	/	Added
		Model PN changed	CDD-CNPNx	CDD-CNPN

Архангельск (8182)63-90-72
 Астана (7172)727-132
 Астрахань (8512)99-46-04
 Барнаул (3852)73-04-60
 Белгород (4722)40-23-64
 Брянск (4832)59-03-52
 Владивосток (423)249-28-31
 Волгоград (844)278-03-48
 Вологда (8172)26-41-59
 Воронеж (473)204-51-73
 Екатеринбург (343)384-55-89
 Иваново (4932)77-34-06

Ижевск (3412)26-03-58
 Иркутск (395)279-98-46
 Казань (843)206-01-48
 Калининград (4012)72-03-81
 Калуга (4842)92-23-67
 Кемерово (3842)65-04-62
 Киров (8332)68-02-04
 Краснодар (861)203-40-90
 Красноярск (391)204-63-61
 Курск (4712)77-13-04
 Липецк (4742)52-20-81
 Киргизия (996)312-96-26-47

Магнитогорск (3519)55-03-13
 Москва (495)268-04-70
 Мурманск (8152)59-64-93
 Набережные Челны (8552)20-53-41
 Нижний Новгород (831)429-08-12
 Новокузнецк (3843)20-46-81
 Новосибирск (383)227-86-73
 Омск (3812)21-46-40
 Орел (4862)44-53-42
 Оренбург (3532)37-68-04
 Пенза (8412)22-31-16
 Казахстан (772)734-952-31

Пермь (342)205-81-47
 Ростов-на-Дону (863)308-18-15
 Рязань (4912)46-61-64
 Самара (846)206-03-16
 Санкт-Петербург (812)309-46-40
 Саратов (845)249-38-78
 Севастополь (8692)22-31-93
 Симферополь (3652)67-13-56
 Смоленск (4812)29-41-54
 Сочи (862)225-72-31
 Ставрополь (8652)20-65-13
 Таджикистан (992)427-82-92-69

Сургут (3462)77-98-35
 Тверь (4822)63-31-35
 Томск (3822)98-41-53
 Тула (4872)74-02-29
 Тюмень (3452)66-21-18
 Ульяновск (8422)24-23-59
 Уфа (347)229-48-12
 Хабаровск (4212)92-98-04
 Челябинск (351)202-03-61
 Череповец (8202)49-02-64
 Ярославль (4852)69-52-93

<http://inventronics.nt-rt.ru/> || ncs@nt-rt.ru