

Description

SDD-AAPNP is the programmer for non-DALI Inventronics drivers, and the programmer and calibrator for the following intelligent controllers:

- SDD-AAPNx Dimming Signal Attenuator
- TDD-ANPNx Combo Dimming Controller



Model

Name	Description	P/N
Programmer	Programmer with calibration function	SDD-AAPNP

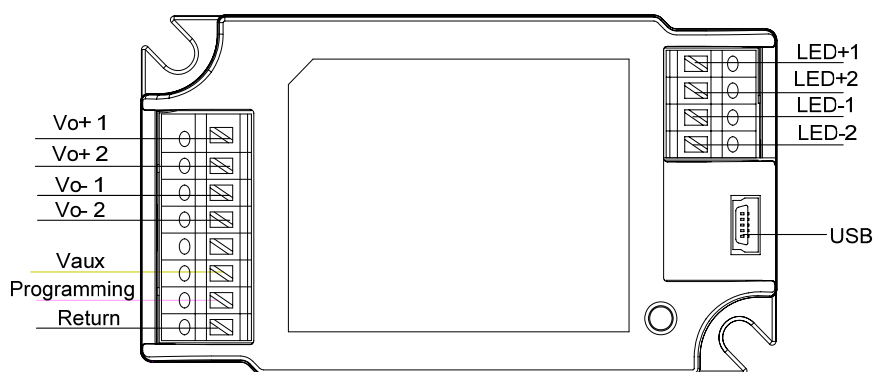

Interface Specifications

Parameter	Min.	Typ.	Max.	Notes
Vaux Voltage	9.8 V	12 V	13.2 V	
Vaux Source Current	0	-	10 mA	
Programming Voltage Rating	0	-	15 V	
Programming Sink Current	0	-	2 mA	
(Vo+ - Vo-) Voltage Rating	0	-	500 V	
(Vo+ - Vo-) Current Rating	0	-	8A/total	4A per Pin
(LED+ - LED-) Voltage	-	(Vo+ - Vo-) Voltage	-	Short circuit protection relies on the protection of the LED driver.
(LED+ - LED-) Current	-	(Vo+ - Vo-) Current	-	

Environmental Specifications

Parameter	Min.	Typ.	Max.	Notes
Operating Ambient Temperature	-20 °C	-	+50 °C	Humidity: 10%RH to 90%RH. No condensation.
Storage Temperature	-40 °C	-	+70 °C	Humidity: 5%RH to 90%RH. No condensation.

Архангельск (8182)63-90-72
Астана (7172)727-132
Астрахань (8512)99-46-04
Барнаул (3852)73-04-60
Белгород (4722)40-23-64
Брянск (4832)59-03-52
Владивосток (423)249-28-31
Волгоград (844)278-03-48
Вологда (8172)26-41-59
Воронеж (473)204-51-73
Екатеринбург (343)384-55-89
Иваново (4932)77-34-06

Ижевск (3412)26-03-58
Иркутск (395)279-98-46
Казань (843)206-01-48
Калининград (4012)72-03-81
Калуга (4842)92-23-67
Кемерово (3842)65-04-62
Киров (8332)68-02-04
Краснодар (861)203-40-90
Красноярск (391)204-63-61
Курск (4712)77-13-04
Липецк (4742)52-20-81
Киргизия (996)312-96-26-47

Магнитогорск (3519)55-03-13
Москва (495)268-04-70
Мурманск (8152)59-64-93
Набережные Челны (8552)20-53-41
Нижегород (831)429-08-12
Новокузнецк (3843)20-46-81
Новосибирск (383)227-86-73
Омск (3812)21-46-40
Орел (4862)44-53-42
Оренбург (3532)37-68-04
Пенза (8412)22-31-16
Казахстан (772)734-952-31

Пермь (342)205-81-47
Ростов-на-Дону (863)308-18-15
Рязань (4912)46-61-64
Самара (846)206-03-16
Санкт-Петербург (812)309-46-40
Саратов (845)249-38-78
Севастополь (8692)22-31-93
Симферополь (3652)67-13-56
Смоленск (4812)29-41-54
Сочи (862)225-72-31
Ставрополь (8652)20-65-13
Таджикистан (992)427-82-92-69

Сургут (3462)77-98-35
Тверь (4822)63-31-35
Томск (3822)98-41-53
Тула (4872)74-02-29
Тюмень (3452)66-21-18
Ульяновск (8422)24-23-59
Уфа (347)229-48-12
Хабаровск (4212)92-98-04
Челябинск (351)202-03-61
Череповец (8202)49-02-64
Ярославль (4852)69-52-93

General Specifications

Parameter	Min.	Typ.	Max.	Notes
Dimensions (L x W x H) Inches Millimeters	3.35 x 1.85 x 0.83 85 x 47 x 21			
Net Weight	-	45 g	-	

Note: All specifications are typical at 25 °C unless otherwise stated.

Packing List

Packing List	Function
SDD-AAPNP	Programmer
USB wire	Connect PC and Programmer
UL Wire with UL female connector	Connect Programmer and SDD-AAPNx or TDD-ANPNx (has male connector)

Programmer Interface Software

From the following website, download and follow the Installation Instructions for Programming Interfaces:
http://www.inventronics-co.com/download.aspx?c_kind=3&c_kind2=17&c_kind3=154

Note the installed software automatically checks for updates over the internet.

Connections

- For programmable drivers, the programming system connection is shown as below.

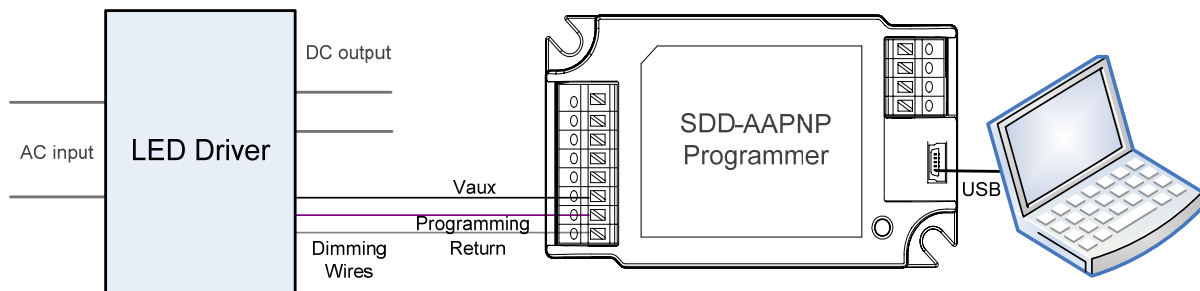

Note: The driver does not need to be powered on during the programming process.

Pin	Connection	Pin	Connection
Vaux	To LED driver's dimming interface (Vaux)	USB	To PC
Programming	To LED driver's dimming interface (Vdim+)	-	-
Return	To LED driver's dimming interface (Vdim-/Return)	-	-

- For SDD-AAPNx and TDD-ANPNx, the programming system connection is shown as below:

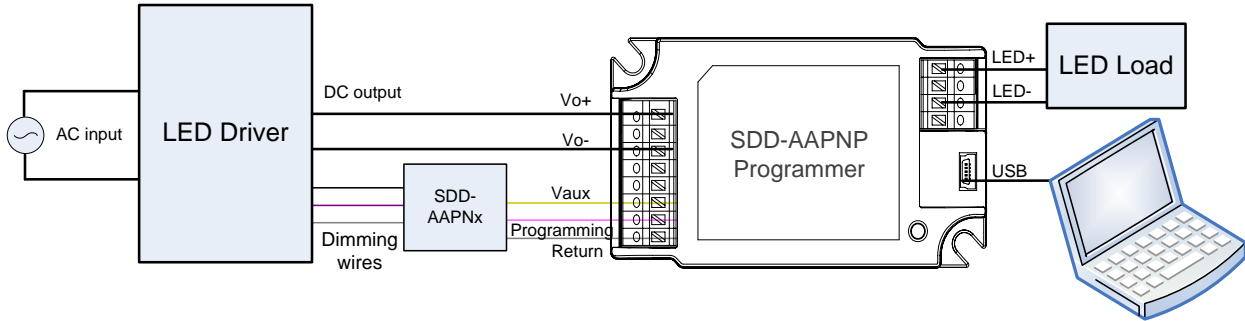

Note: The driver needs to be powered on during the programming process. The driver output and the LED load must be connected for calibration of the output-current setting.

Pin	Connection	Pin	Connection	Pin	Connection
Vo+1,2	To LED driver's output Vo+	LED+1,2	To LED+	USB	To PC
Vo-1,2	To LED driver's output Vo-	LED-1,2	To LED-	-	-
Vaux	To LED driver's dimming interface (Vaux)	-	-	-	-
Programming	To LED driver's dimming interface (Vdim+)	-	-	-	-
Return	To LED driver's dimming interface (Vdim-/Return)	-	-	-	-

PC interface

- Inventronics Programmable LED Drivers

Example:

The following is the detailed settings in the below picture:

LED driver model: EUD-200S245DT

Maximum current setting: 1.96A

Dimming setting: 0-10V dimming

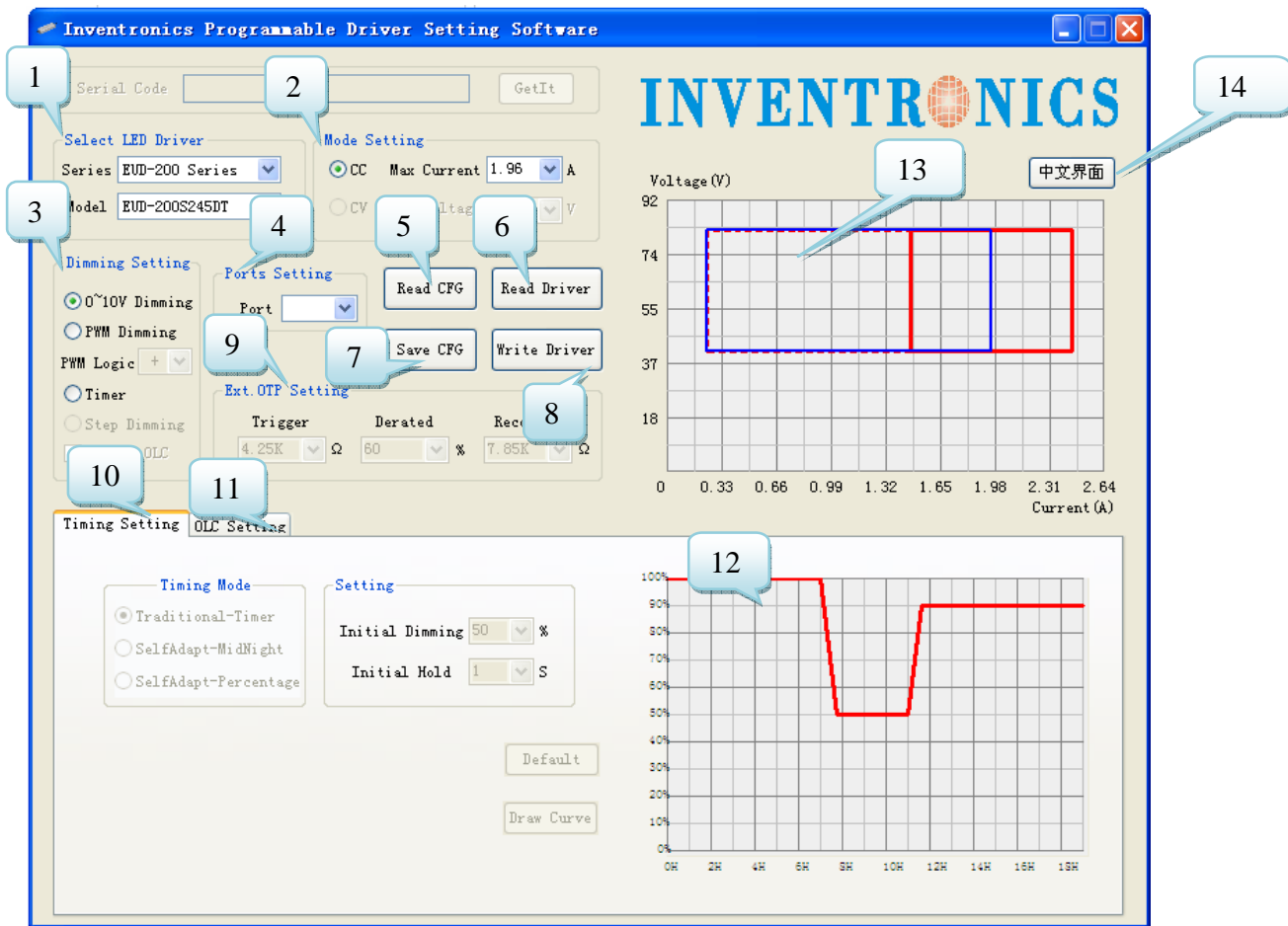

Functions in the software interface (not available if the font is gray):

Item	Name	Description
1	Select LED Driver	Select the LED driver series and model
2	Mode setting	Set the mode (constant current or voltage) and maximum value
3	Dimming Setting	Set the dimming mode, which can be 0-10V dimming, PWM dimming, timer, Output Lumen Compensation (OLC), etc
4	Ports Setting	Set the communication port. If only one programmer is connected, it will be set automatically
5	Read CFG	Load the user setting configuration file from PC
6	Read Driver	Read the configuration from driver
7	Save CFG	Save the user setting configuration file to PC
8	Write Driver	Write the configuration to the driver
9	Ext. OTP Setting	Set the parameters of an external Over Temperature Protection if the driver has this feature

Item	Name	Description
10	Timing Setting	Set the timing mode and curve
11	OLC Setting	Set the Output Lumen Compensation
12	Timing curve	Displays the curve of driver output vs. time (hours)
13	Operating Area	Displays the possible combinations of output voltage and current: Dashed line shows the maximum possible operating area Red line shows the good performance area (power factor & THD) Blue line shows the programmed operating area
14	中文界面	Shift to Chinese Version

Time Dimming Interface

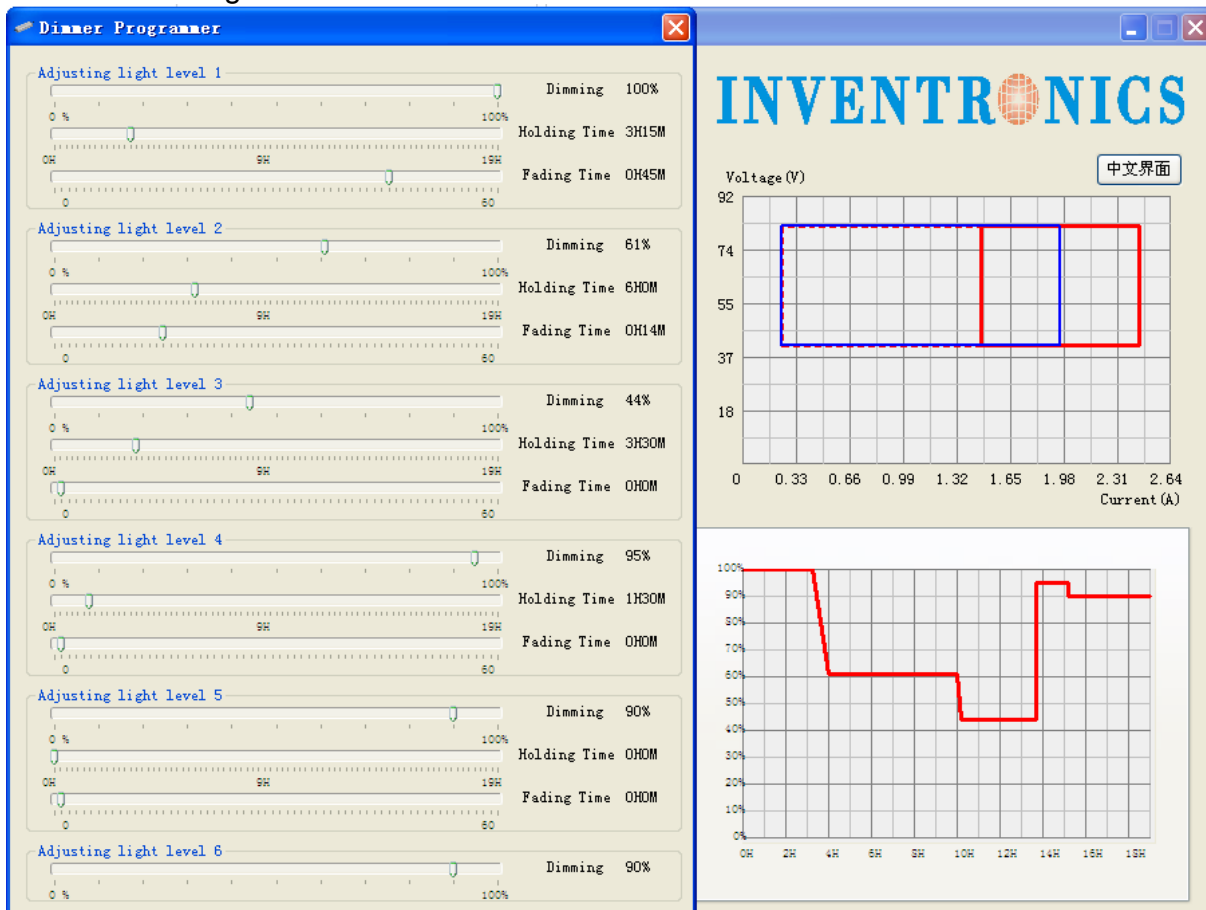

Set the timing curve by moving the sliders.

- SDD-AAPNx Dimming Signal Attenuator

Example:

The following is the detailed settings in the below picture:

LED driver model: EUC-075S105DT

Maximum current setting: 0.9A

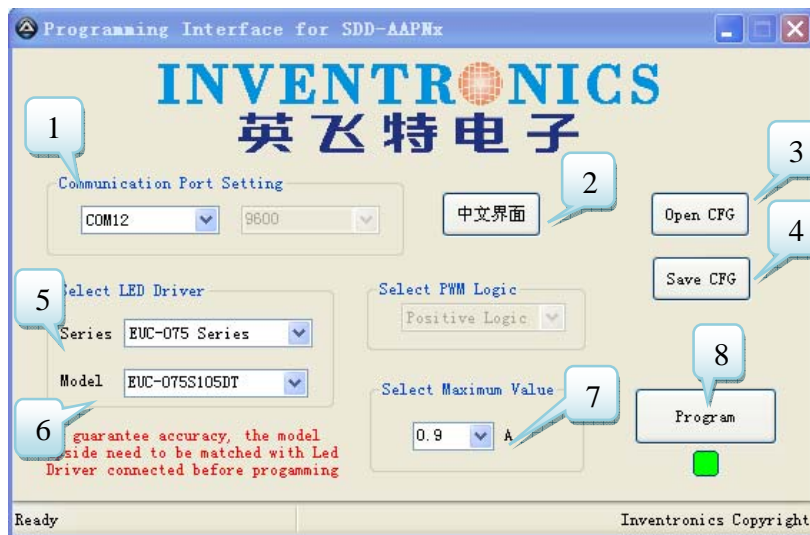

Item	Name	Description	Note
1	Communication Port	If only one programmer is connected, it will be set automatically.	
2	中文界面	Shift to Chinese Version	
3	Open CFG	Load the user setting configuration file from PC	
4	Save CFG	Save the user setting configuration file to PC	
5	Series	Select the LED driver series	
6	Model	Select the driver model (after selecting the series)	
7	Select Maximum Value	Set the maximum value of output current	
8	Program	Write the maximum value to the driver and calibrate	

- TDD-ANPNx Combo Dimming Controller

Example:

The following is the detailed settings in the below picture:

LED driver model: EUC-075S035DT

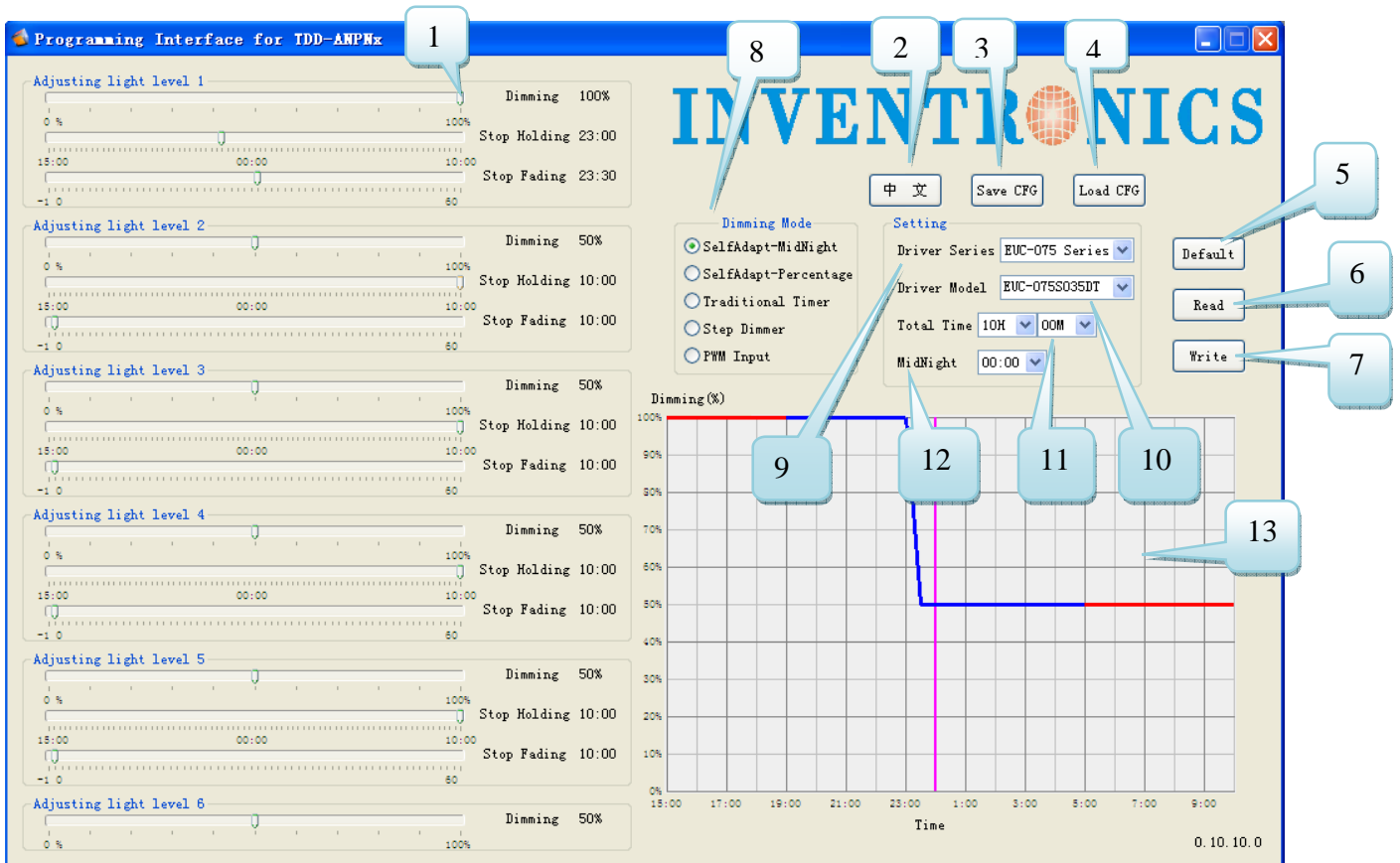

Item	Name	Description	Note
1	Slider	Set timing curve – Load, holding time and fade time, up to 6 segments can be set	
2	中文	Shift to Chinese Version	
3	Save CFG	Save the user setting configuration file to PC	
4	Load CFG	Load the user setting configuration file from PC	
5	Default	Return to default configuration	
6	Read	Read timer setting configuration from timer to PC	
7	Write	Write timer setting configuration from PC to timer	
8	Dimming Mode	<ol style="list-style-type: none"> Self adapting-Midnight: Automatically adjusts the dimming curve based on the on-time of past two days (if difference <15 minutes), assuming that the center point of the dimming curve is midnight local time Self adapting-Percentage: Automatically adjusts the on-time of each step by a constant percentage = (actual on-time for the past 2 days if difference <15 min) / (programmed on-time from the dimming curve) Traditional Timer: Follows the programmed timing curve after power on with no changes Step Dimmer: Turning the input power off/on once changes to the next dimming level; up to 6 steps are available PWM Input: Compatible with PWM control signals with positive or negative logic 	

Item	Name	Description	Note
9	Driver series	Select the LED driver series	
10	Driver model	Select the driver model (after selecting the series)	
11	Total time	Initial on-time setting for the two self-adaptive modes	
12	Midnight	Set the midnight point as a start reference	For self adapt-midnight mode only.
13	Curve	Display the timing curve	

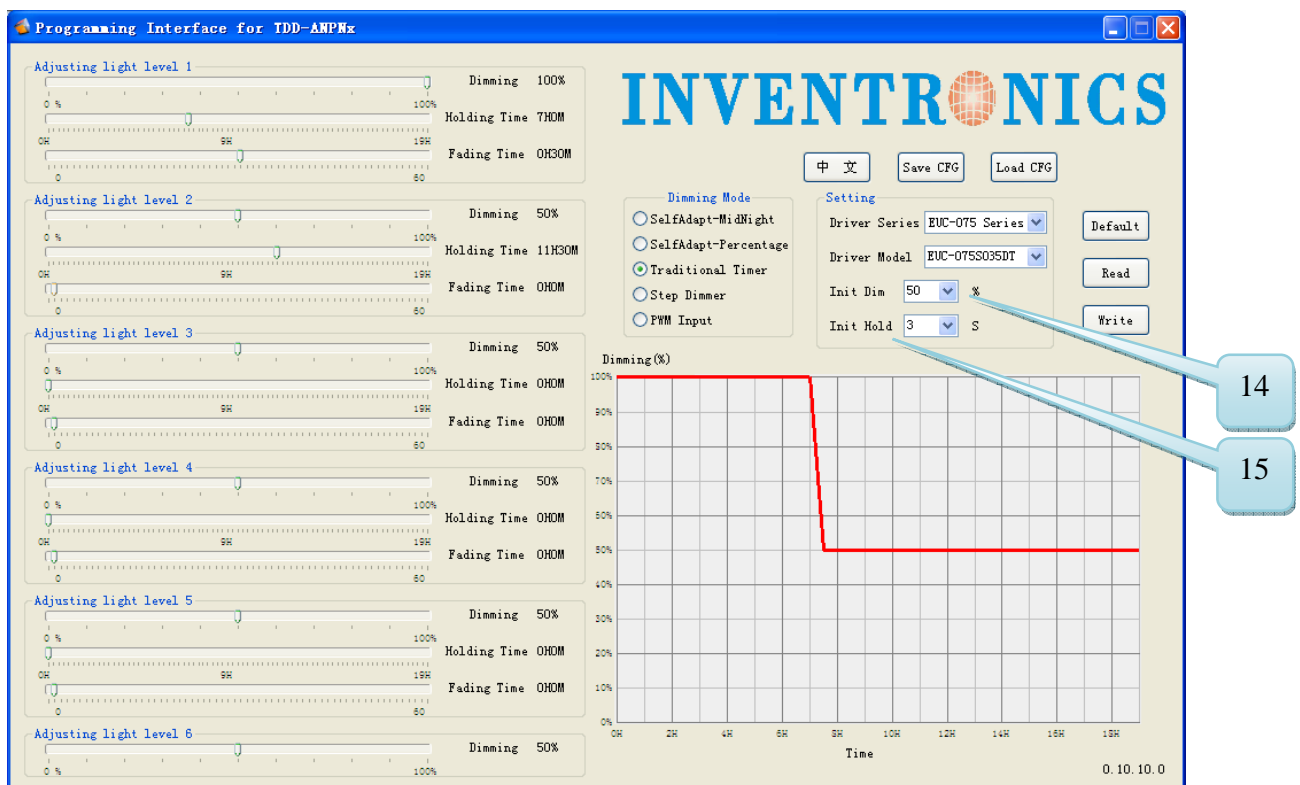

Item	Name	Description	Note
14	Init Dim	Set initial dimming level before running the curve	This is for the software write verification.
15	Init Hold	Set the hold time for Initial dimming level	

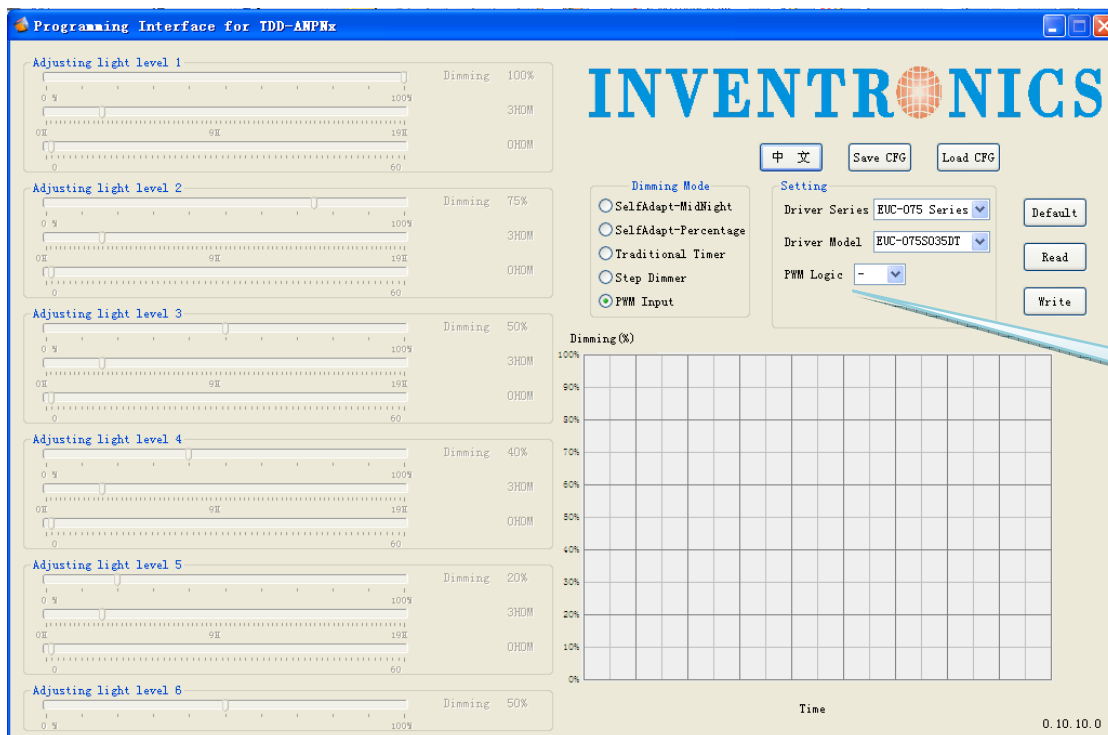
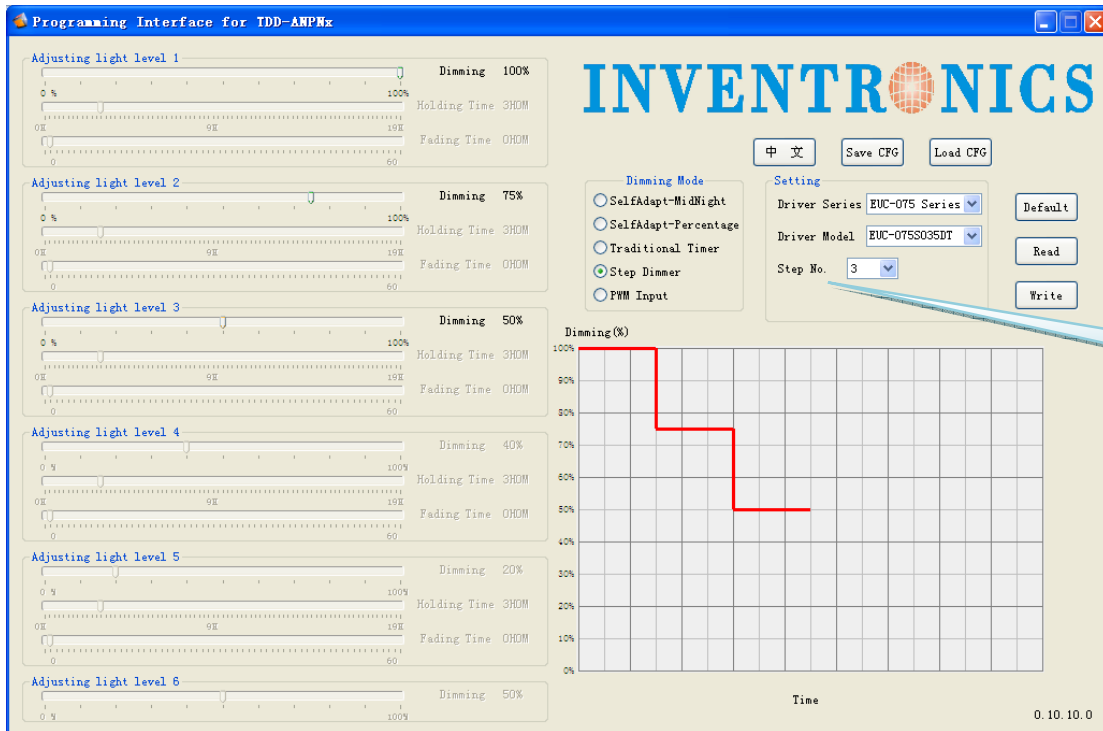

Item	Name	Description	Note
16	Step No.	Set the step dimming level count, and each level can be programmed	For step dimming mode only.
17	PWM logic	Set the logic of PWM input signal	PWM Input

Mechanical Outline

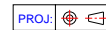
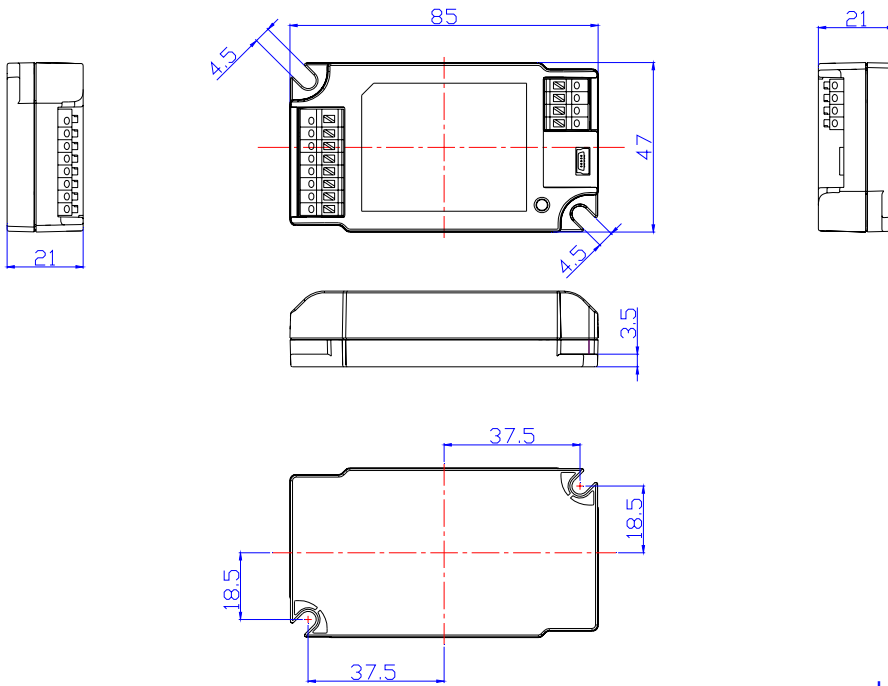

Unspecified tolerance: ±1

RoHS Compliance

Our products comply with the European Directive 2011/65/EC, calling for the elimination of lead and other hazardous substances from electronic products.

Revision History

Change Date	Rev.	Description of Change		
		Item	From	To
2013-09-23	A	Datasheets Release	/	/
2013-12-11	B	Interface specification	/	Added
		Operating temperature	/	Updated
2014-07-28	C	Dimensions	/	Added
		Net Weight	/	Added
		PC Interface of SDD-AAPNx and TDD-ANPNx	/	Added

Архангельск (8182)63-90-72
 Астана (7172)727-132
 Астрахань (8512)99-46-04
 Барнаул (3852)73-04-60
 Белгород (4722)40-23-64
 Брянск (4832)59-03-52
 Владивосток (423)249-28-31
 Волгоград (844)278-03-48
 Вологда (8172)26-41-59
 Воронеж (473)204-51-73
 Екатеринбург (343)384-55-89
 Иваново (4932)77-34-06

Ижевск (3412)26-03-58
 Иркутск (395)279-98-46
 Казань (843)206-01-48
 Калининград (4012)72-03-81
 Калуга (4842)92-23-67
 Кемерово (3842)65-04-62
 Киров (8332)68-02-04
 Краснодар (861)203-40-90
 Красноярск (391)204-63-61
 Курск (4712)77-13-04
 Липецк (4742)52-20-81
 Киргизия (996)312-96-26-47

Магнитогорск (3519)55-03-13
 Москва (495)268-04-70
 Мурманск (8152)59-64-93
 Набережные Челны (8552)20-53-41
 Нижний Новгород (831)429-08-12
 Новокузнецк (3843)20-46-81
 Новосибирск (383)227-86-73
 Омск (3812)21-46-40
 Орел (4862)44-53-42
 Оренбург (3532)37-68-04
 Пенза (8412)22-31-16
 Казахстан (772)734-952-31

Пермь (342)205-81-47
 Ростов-на-Дону (863)308-18-15
 Рязань (4912)46-61-64
 Самара (846)206-03-16
 Санкт-Петербург (812)309-46-40
 Саратов (845)249-38-78
 Севастополь (8692)22-31-93
 Симферополь (3652)67-13-56
 Смоленск (4812)29-41-54
 Сочи (862)225-72-31
 Ставрополь (8652)20-65-13
 Таджикистан (992)427-82-92-69

Сургут (3462)77-98-35
 Тверь (4822)63-31-35
 Томск (3822)98-41-53
 Тула (4872)74-02-29
 Тюмень (3452)66-21-18
 Ульяновск (8422)24-23-59
 Уфа (347)229-48-12
 Хабаровск (4212)92-98-04
 Челябинск (351)202-03-61
 Череповец (8202)49-02-64
 Ярославль (4852)69-52-93